

Register 20

CONTENTS - Sampling valve type AtoPro

Contents	Page
<i>Technical Data AtoPro, metallic</i>	2
<i>Material Specification AtoPro, metallic</i>	3
<i>Assembly Instructions AtoPro, metallic</i>	4
<i>Disassembly Instruction AtoPro, metallic</i>	5
<i>Necessary Actuator Torques AtoPro, metallic</i>	6
<i>Recommended Tightening Torques AtoPro, metallic</i>	6
<i>Technical Data AtoPro, lined</i>	7
<i>Material Specification AtoPro, lined</i>	8
<i>Assembly Instructions AtoPro, lined</i>	9
<i>Disassembly Instruction AtoPro, lined</i>	10
<i>Necessary Actuator Torques AtoPro, lined</i>	11
<i>Recommended Tightening Torques AtoPro, lined</i>	11
<i>AtoPro Accessories</i>	12
<i>AtoPro Protection Box (Cabinet)</i>	13
<i>AtoPro Protection Box (Cabinet) - Disassembly Instruction</i>	14
<i>Sampling with the AtoPro</i>	15

Technical Data AtoPro, metallic

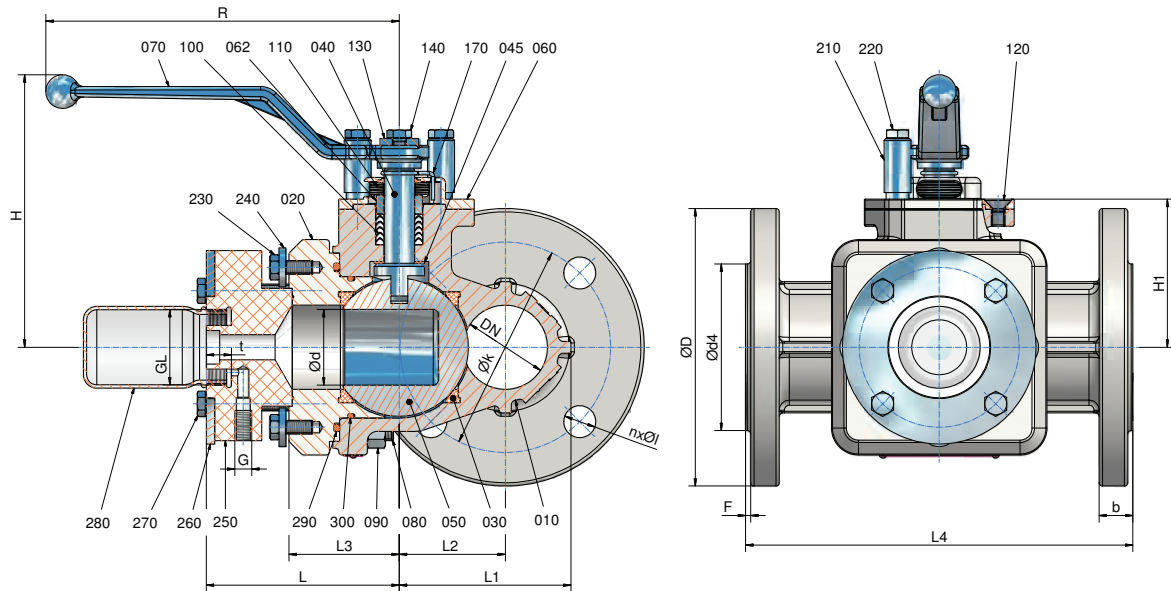

DN		L	L ₁	L ₂	L ₃	L ₄	H	t	G	H1
025	mm	114,5	77	50	65,5	160	162	15	M10	88
	inch	4,51	3,03	1,97	2,58	6,3	6,38	0,59		3,46
050	mm	114,5	102	63	65,5	230	162	15	M10	88
	inch	4,51	4,02	2,48	2,58	9,06	6,38	0,59		3,46
080	mm	114,5	133	78	65,5	310	162	15	M10	88
	inch	4,51	5,24	3,07	2,58	12,2	6,38	0,59		3,46

DN	R	GL Din 168-1	weight		DN	Ød	optional Sampling- Vol. cm ³
025	mm	210	kg	7,2	025, 050, 080	mm	15
	inch	8,3	lbs	15,8		inch	0,79
050	mm	210	kg	16,6		mm	45
	inch	8,27	lbs	36,6		inch	1,34
080	mm	210	kg	21,6		mm	90
	inch	8,27	lbs	47,6		inch	1,77

Material specification AtoPro, metallic

No.	Designation	Pieces	Material	Material-No. / DIN	ASTM / AISI
010	body	1	stainless steel	1.4408 / DIN EN 10213-4	A744 CF-8M
020	flange	1	stainless steel	1.4408 / DIN EN 10213-4	A744 CF-8M
030	seat ring	2	PTFE° / PTFE-graphite°		
040	stem	1	stainless steel	1.4571 / DIN EN 10088-1	A276 316
045	back-up ring	1	PTFE		
050	ball	1	stainless steel	1.4571 / DIN EN 10088-1	A276 316
060	top cap	1	stainless steel	1.4308 / DIN EN 10283	A 743 CF-8
061	bushing	1	PTFE		
062	spacer	1	stainless steel	1.4104 / DIN EN 10088-3	AISI 430F
070	hand lever	1	stainless steel	1.4308 / DIN EN 10283	A 743 CF-8
080	stud bolt	1 set	stainless steel	1.4301 / DIN EN 10088-3	A 193 B8
090	hexagon nut	1 set	stainless steel	1.4301 / DIN EN 10088-3	A 194 8
100	packing material (chevron)	1 set	PTFE ° PTFE-graphite°		
110	belleville washer	1 set	stainless steel	1.4310 / DIN EN 10270-3	AISI 301
120	countersunk screw	2	stainless steel	1.4301 / DIN EN 10088-3	A 193 B8
130	washer	1	stainless steel	1.4301 / DIN EN 10088-3	AISI 304
140	hexagon bolt	1	stainless steel	1.4301 / DIN EN 10088-3	A 193 B8
170	grounding device	1	stainless steel	1.4310 / DIN EN 10270-3	AISI 301
210	stop	2	stainless steel	1.4301 / DIN EN 10088-3	AISI 304
220	hexagon bolt	2	stainless steel	1.4301 / DIN EN 10088-3	A 193 B8
230	hexagon bolt	1 set	stainless steel	1.4301 / DIN EN 10088-3	A 193 B8
240	washer	1 set	stainless steel	1.4301 / DIN EN 10088-3	AISI 304
250	adapter	1	PTFE° / PTFE-graphite°		
260	plate	1	stainless steel	1.4301 / DIN EN 10088-3	AISI 304
270	hexagon bolt	1 set	stainless steel	1.4301 / DIN EN 10088-3	A 193 B8
280	bottle	1	glass (100ml)		
290	O-ring	1	Viton		
300	O-ring	1	Viton		

° optional

Assembly Instructions AtoPro, metallic

The general installation and maintenance instructions must be observed.

1. Insert stem **(040)** and backup ring **(045)** from inside of the body **(010)** in such a way that the flats of the stem are parallel to the body longitudinal axis.
2. Insert chevron packing **(100)** and spacer **(062)**.
3. Install belleville washers **(110)** in alternating arrangement on spacer.
4. Install top cap **(060)** and bushing **(061)** using the countersunk screws **(120)**.
5. Install grounding device **(170)** also on gear or automated valves.
6. Install hand lever **(070)** on to stem **(040)** using the washer **(130)** and hexagon screw **(140)**.
7. Insert first seat ring **(030)** into the body **(010)**.
8. Insert ball **(050)** to the stem by pushing the ball in a downward motion through valve body.
9. Turn hand lever to the 90° -position, longitudinal axis of body.
10. Place the second seat ring **(030)** on to ball **(050)**.
11. Install the O-rings **(290, 300)** in the provided slots of the flange **(020)**.
12. The studs **(080)** are to be screwed into the flange **(020)**.
13. Install the flange **(020)** to the body **(010)**.
14. Tighten the hexagon nuts **(050)** using the recommended torques with the crisscross method.
15. Install the hexagon screws **(230)** with the washer **(240)**.
16. Install the stop **(210)** using the hexagon screw **(220)**.
17. Install the adapter **(250)** using the plate **(260)** and the hexagon screws **(270)**.
18. Screw the bottle **(280)** into the adapter **(250)**.

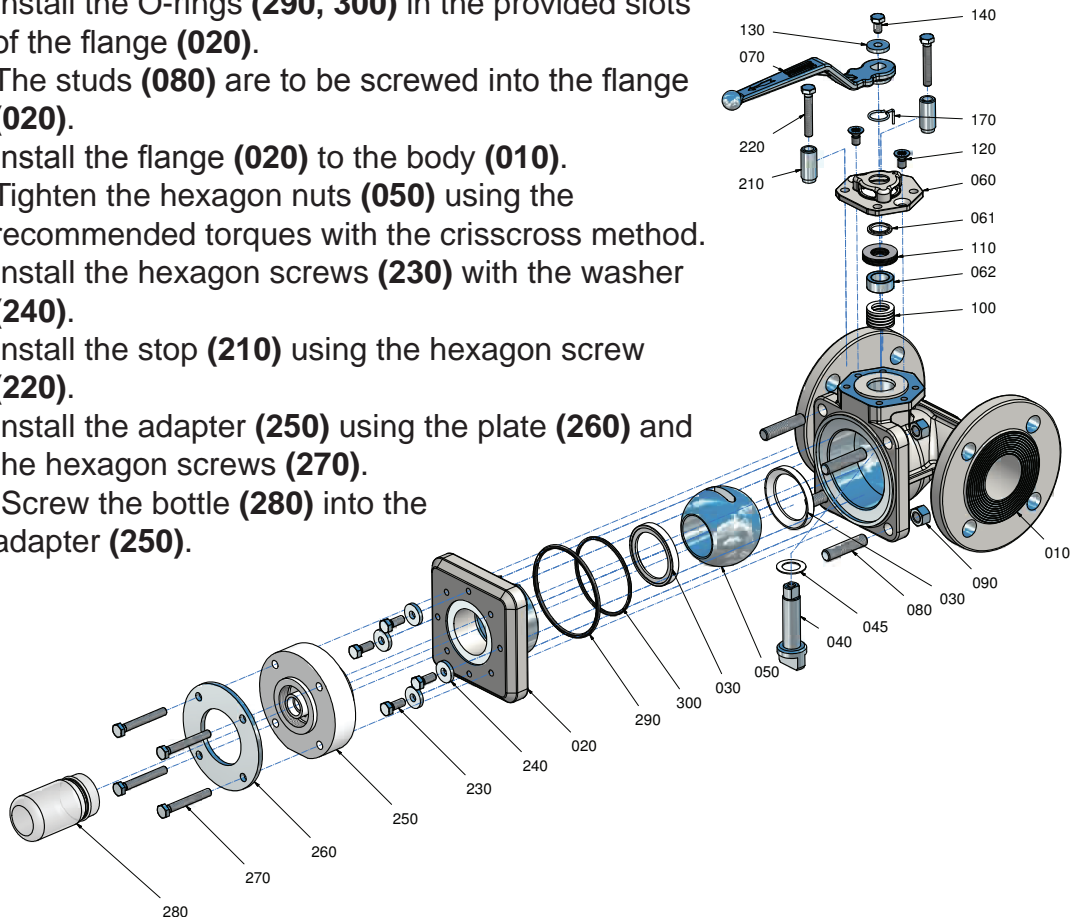

Disassembly Instructions AtoPro, metallic

For all jobs which are to be carried out on an installed valve, the works safety requirements and the general accident prevention instructions must be observed. Moreover, the general installation and maintenance instructions for fluorocarbon resin-lined atomac valves must be considered.

1. Prior to disassembly, the valve must be cleaned from all fluid according to the above mentioned instructions. Remove the bottle **(280)**. Particular care must be taken that during the rinsing and draining of the piping, the valve is opened and closed repeatedly. Only when following this procedure, it is ensured that all remaining pressure inside the body is eliminated.
2. Put the valve on a work bench with a soft cover (rubber mat).
3. Remove the adapter **(250)** and plate **(260)** by unscrewing the hexagon bolts **(270)** out of the flange **(020)**.
4. Remove hexagon bolts **(230)** and washers **(240)**.
5. Hexagon nuts **(090)** must be removed to get the flange **(020)** with the O-rings **(290, 300)** disassembled from the body **(010)**.
6. Remove first seat ring **(030)** out of the flange **(020)**.
7. The ball **(050)** in closed position can easily be pushed out of the body **(010)**.
8. The second seat ring **(030)** can be removed out of the body **(010)**.
9. Remove the hand lever **(070)**.
10. Remove the grounding spring **(170)** from the top cap **(060)**.
11. Disassemble the stop **(210)**
12. Retighten the countersunk screws **(120)** and remove the top cap **(060)** with the bushing **(061)**, the belleville washers **(110)** and spacer **(062)**.
13. Remove the stem **(040)** with the backup ring **(045)** by pushing it down through the body **(010)**.
14. The Chevron packing **(100)** can easily be removed.

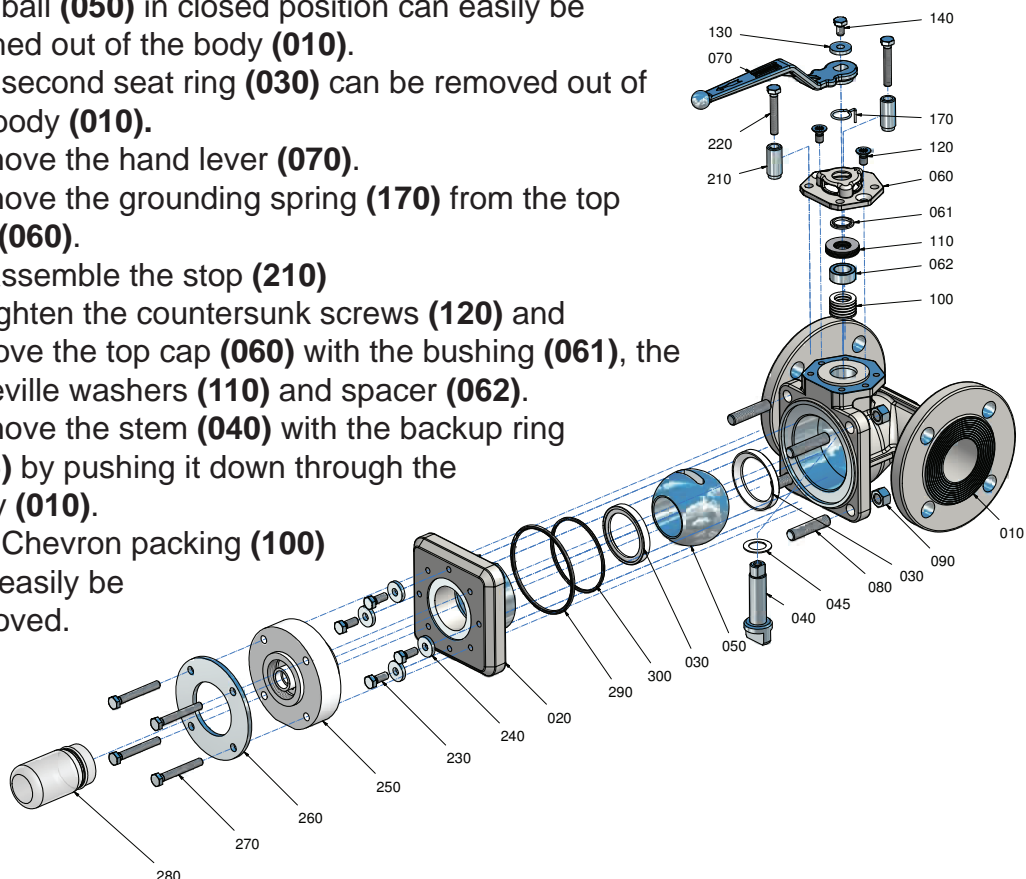

AtoPro, metallic necessary actuator torques

Packingmaterial: chevron PTFE or PTFE-graphite

Size	0 bar Δp Nm	0 psi Δp in/ lbs
025	30	266
050	30	266
080	30	266

*Test medium is air.
Test temperature is 20°C (68°F).*

AtoPro, metallic recommended tightening torques*

DN	tie rods (080/090)	
	Nm	in.lbs
025	80	708
050	80	708
080	80	708

* *maximum values*

Technical Data AtoPro, lined

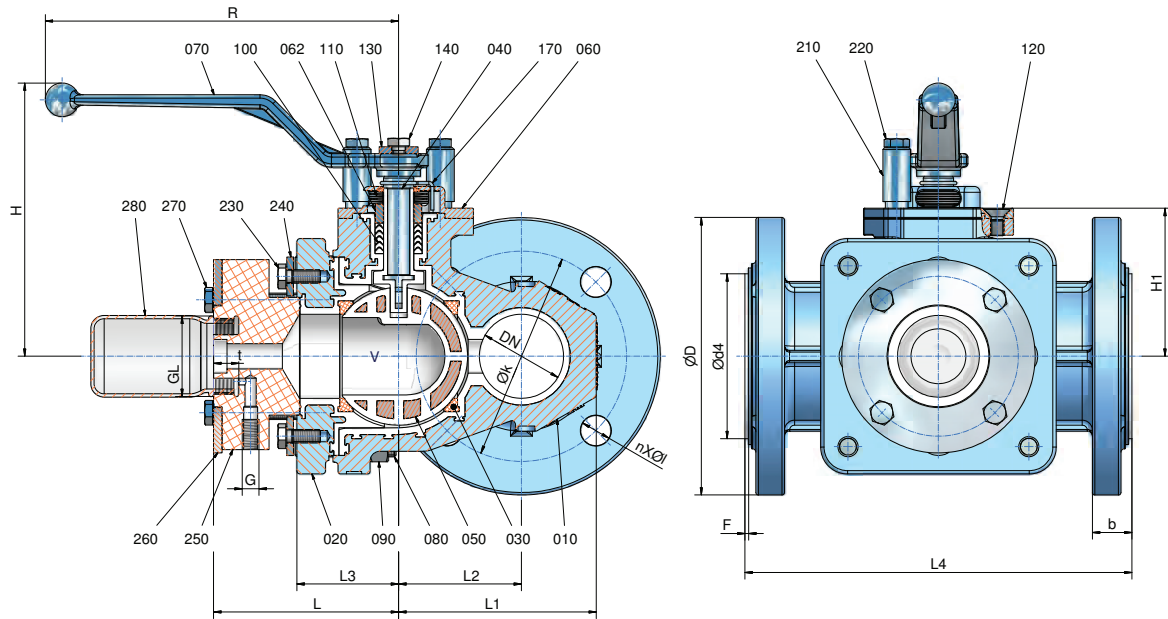

DN		L	L1	L2	L3	L4	H	H1	b	t	G
025	mm	109,5	90,5	60	60,5	160	160	88	21	15	M10
	inch	4,31	3,56	2,36	2,38	6,3	6,3	3,46	0,83	0,59	
050	mm	109,5	117,5	73	60,5	230	160	88	23,5	15	M10
	inch	4,31	4,63	2,87	2,38	9,06	6,3	3,46	0,93	0,59	
080	mm	109,5	148,5	88	60,5	310	160	88	31,5	15	M10
	inch	4,31	5,85	3,46	2,38	12,2	6,3	3,46	1,24	0,59	

DN		R	GL DIN 168-1	nxØ1	Øk	ØD	Ød4	F	weight	
025	mm	210	GL45	4x14	85	115	65	2	kg	14,6
	inch	8,27	GL45	4x0,55	3,35	4,53	2,56	0,08	lbs	32,2
050	mm	210	GL45	4x18	125	165	98	2	kg	19,6
	inch	8,27	GL45	4x0,71	4,92	6,5	3,86	0,08	lbs	43,2
080	mm	210	GL45	8x19	160	200	133	2	kg	26,0
	inch	8,27	GL45	8x0,75	6,3	7,87	5,24	0,08	lbs	57,3

DN	Ød	optional Sampling-Vol. cm ³
080	mm	22
	inch	0,87
025, 050, 080	mm	34
	inch	1,34
025, 050, 080	mm	48
	inch	1,89

Technical Manual

Material specification AtoPro, lined

No.	Designation	Pieces	Material	Material-No. / DIN	ASTM / AISI
010	body	1	ductile iron / PFA [°] ductile iron / PFA-conductive [°]	EN-JS1049 (GGG-40.3) / DIN EN 1563	A 395
020	flange	1	ductile iron / PFA [°] ductile iron / PFA-conductive [°]	EN-JS1049 (GGG-40.3) / DIN EN 1563	A 395
030	seat ring	2	PTFE [°] / PTFE-conductive [°]		
040	stem	1	stainless steel / PFA / PFA-conductive [°]	1.4470 / DIN EN 10283	A 890
050	ball	1	tool steel, alloyed / PFA [°] / PFA-conductive [°]	1.2343 / DIN EN ISO 4957	A 646-95
060	top cap	1	stainless steel	1.4308 / DIN EN 10283	A 743 CF-8
061	bushing	1	PTFE [°] / PTFE-conductive [°]		
062	spacer	1	stainless steel	1.4104 / DIN EN 10088-3	AISI 430F
070	hand lever	1	die cast metall	ZP0410 / DIN EN 12844	
080	stud bolt	1 set	stainless steel	1.4301 / DIN EN 10088-3	A 193 B8
090	hexagon nut	1 set	stainless steel	1.4301 / DIN EN 10088-3	A 193 8
100	packing material	1 set	PTFE [°] / PTFE-conductive [°]		
110	belleville washer	1 set	stainless steel	1.4310 / DIN EN 10270-3	AISI 301
120	countersunk screw	2	stainless steel	1.4301 / DIN EN 10088-3	A 193 B8
130	flat washer	1	stainless steel	1.4301 / DIN EN 10088-3	AISI 304
140	hexagon bolt	1	stainless steel	1.4301 / DIN EN 10088-3	A 193 B8
170	grounding device	1	stainless steel	1.4310 / DIN EN 10270-3	AISI 301
210	stop	2	steel (galvanized)	1.0037 / DIN EN 10025-2	A 283 B
220	hexagon bolt	2	stainless steel	1.4301 / DIN EN 10088-3	A 193 B8
230	hexagon bolt	1 set	stainless steel	1.4301 / DIN EN 10088-3	A 193 B8
240	flat washer	1 set	stainless steel	1.4301 / DIN EN 10088-3	AISI 304
250	adapter	1	PTFE [°] / PTFE-conductive [°]		
260	plate	1	stainless steel	1.4301 / DIN EN 10088-3	AISI 304
270	hexagon bolt	1 set	stainless steel	1.4301 / DIN EN 10088-3	A 193 B8
280	bottle	1	glass (100ml)		

[°] optional

Assembly Instructions AtoPro, lined

The general installation and maintenance instructions must be observed.

1. Insert stem **(040)** from inside of the body **(010)** in such a way that the flats of the stem are parallel to the body longitudinal axis.
2. Insert chevron packing **(100)** and spacer **(062)**.
3. Install belleville washer **(110)** in alternating arrangement on spacer.
4. Install top cap **(060)** and bushing **(061)** using the countersunk screws **(120)**.
5. Install grounding device **(170)** also on gear or automated valves.
6. Install hand lever **(070)** on to stem **(040)** using the washer **(130)** and hexagon screw **(140)**.
7. Insert first seat ring **(030)** into the body **(010)**.
8. Insert ball **(050)** to the stem by pushing the ball in a downward motion through valve body.
9. Turn hand lever to the 90° -position, longitudinal axis of body.
10. Place the second seat ring **(030)** on to ball **(050)**.
11. The studs **(080)** are to be screwed into the flange **(020)**.
12. Install the flange **(020)** to the body **(010)**.
13. Tighten the hexagon nuts **(090)** using the recommended torques with the crisscross method.
14. Install the hexagon screws **(230)** with the washer **(240)**.
15. Install the stop **(210)** using the hexagon screw **(220)**.
16. Install the adapter **(250)** using the plate **(260)** and the hexagon screws **(270)**.
17. Screw the bottle **(280)** into the adapter **(250)**.

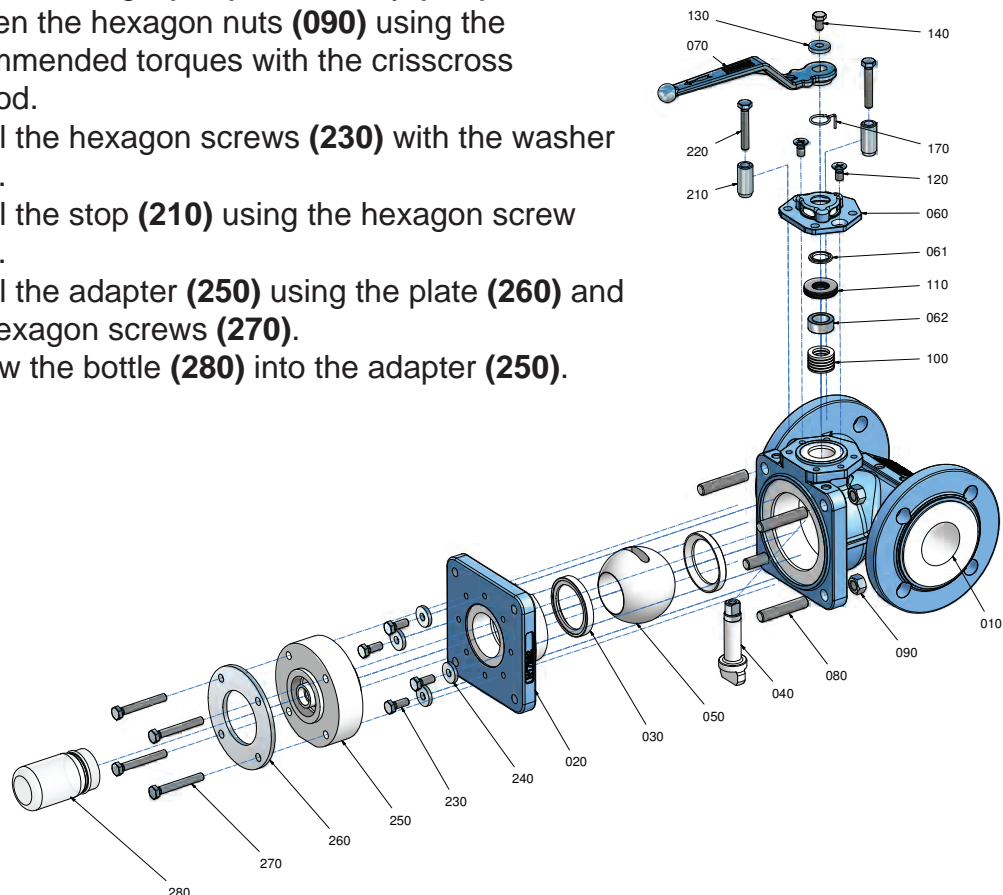

Disassembly Instructions AtoPro, lined

For all jobs which are to be carried out on an installed valve, the works safety requirements and the general accident prevention instructions must be observed. Moreover, the general installation and maintenance instructions for fluorocarbon resin-lined atomac valves must be considered.

1. Prior to disassembly, the valve must be cleaned from all fluid according to the above mentioned instructions. Remove the bottle **(280)**. Particular care must be taken that during the rinsing and draining of the piping, the valve is opened and closed repeatedly. Only when following this procedure, it is ensured that all remaining pressure inside the body is eliminated.
2. Put the valve on a work bench with a soft cover (rubber mat).
3. Remove the adapter **(250)** and plate **(260)** by unscrewing the hexagon bolts **(270)** out of the flange **(020)**.
4. Remove hexagon bolts **(230)** and washers **(240)**.
5. Hexagon nuts **(090)** must be removed to get the flange **(020)** disassembled from the body **(010)**.
6. Remove first seat ring **(030)** out of the flange **(020)**.
7. The ball **(050)** in closed position can easily be pushed out of the body **(010)**.
8. The second seat ring **(030)** can be removed out of the body **(010)**.
9. Remove the hand lever **(070)**.
10. Remove the grounding spring **(170)** from the top cap **(060)**.
11. Disassemble the stop **(210)**
12. Retighten the countersunk screws **(120)** and remove the top cap **(060)** with the bushing **(061)**, the belleville washers **(110)** and spacer **(062)**.
13. Remove the stem **(040)** by pushing it down through the body **(010)**.
14. The Chevron packing **(100)** can easily be removed.

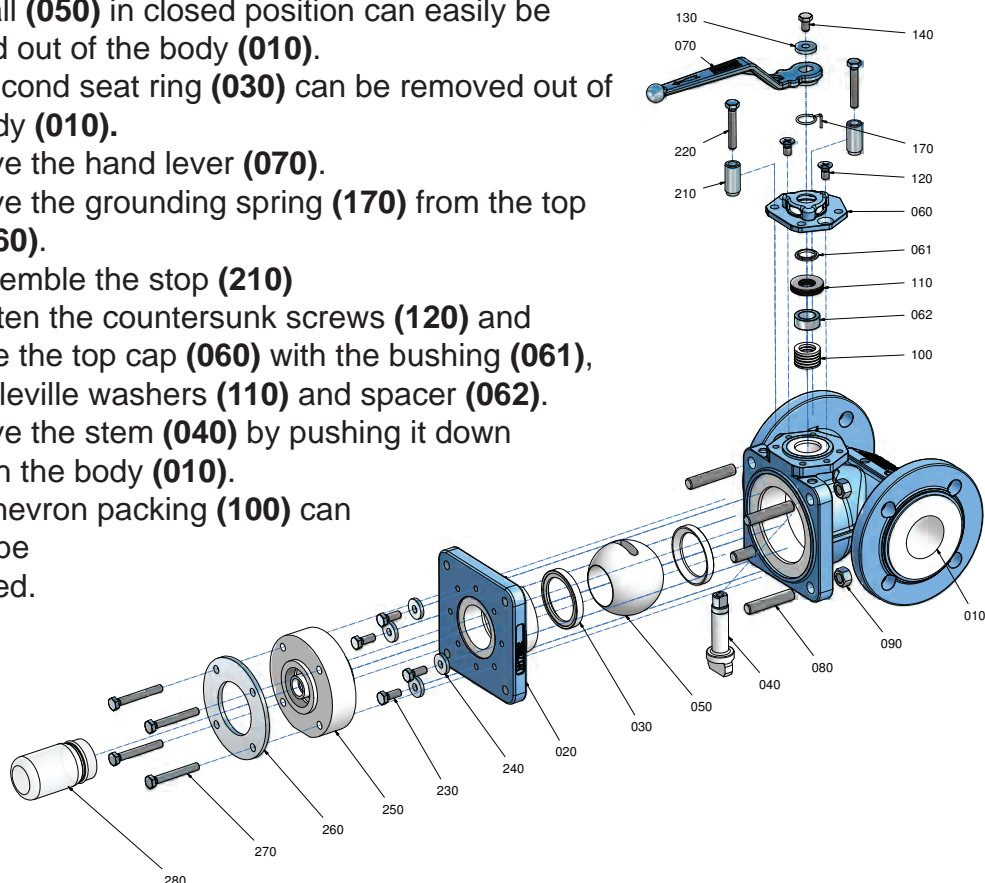

AtoPro, lined necessary actuator torques

Packingmaterial: chevron PTFE or PTFE-graphite

Size	0 bar Δp Nm	0 psi Δp in/ lbs
025	30	266
050	30	266
080	30	266

Test medium is air.

Test temperature is 20°C (68°F).

Please note the conditions of service temperatur-diagrams of pressure/vacuum: register 1, page 13.

AtoPro, lined recommended tightening torques*

DN	tie rods (080/090)	
	Nm	in.lbs
025	80	708
050	80	708
080	80	708

* maximum values

AtoPro, Accessories

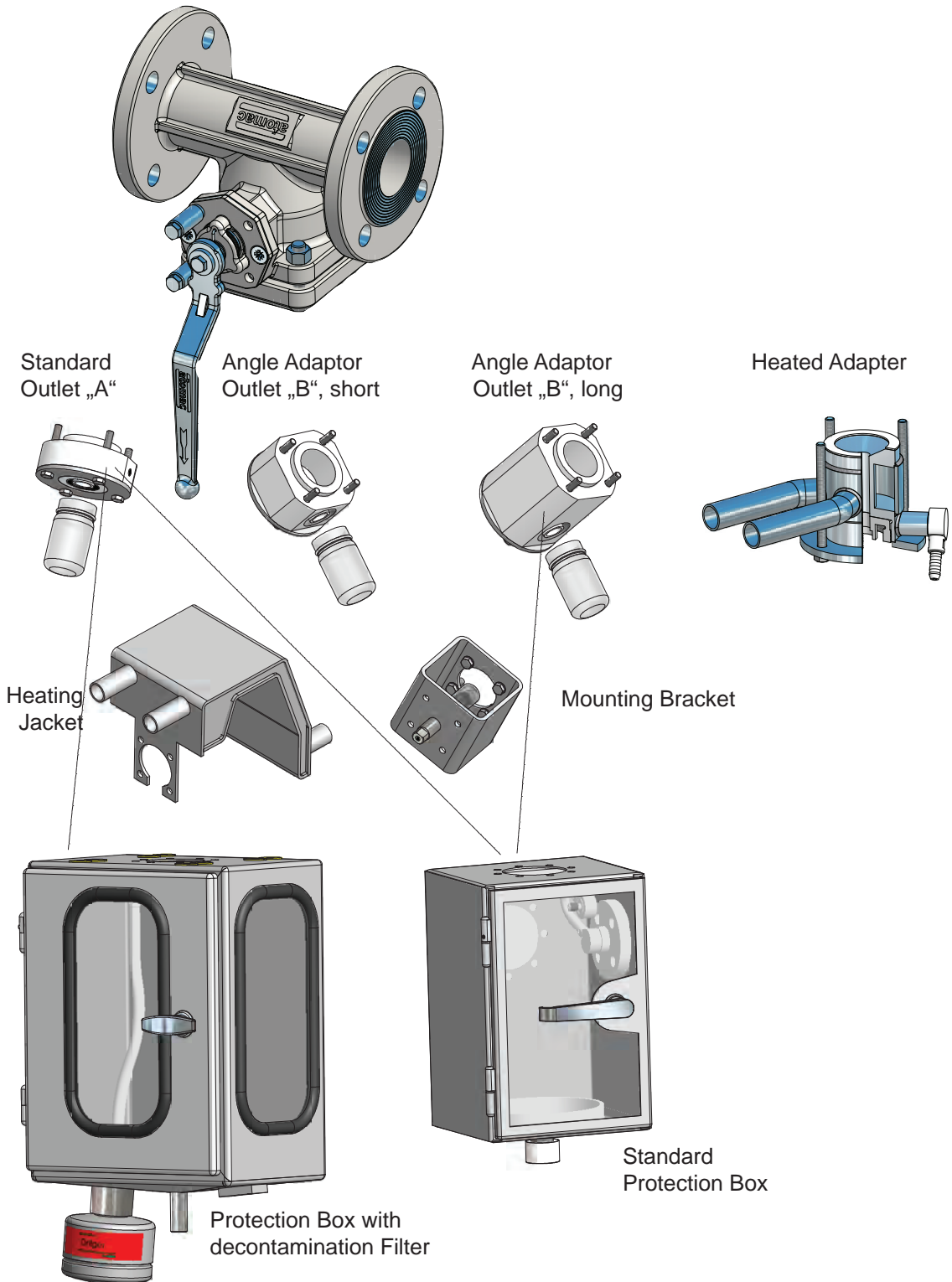

AtoPro Protection Box

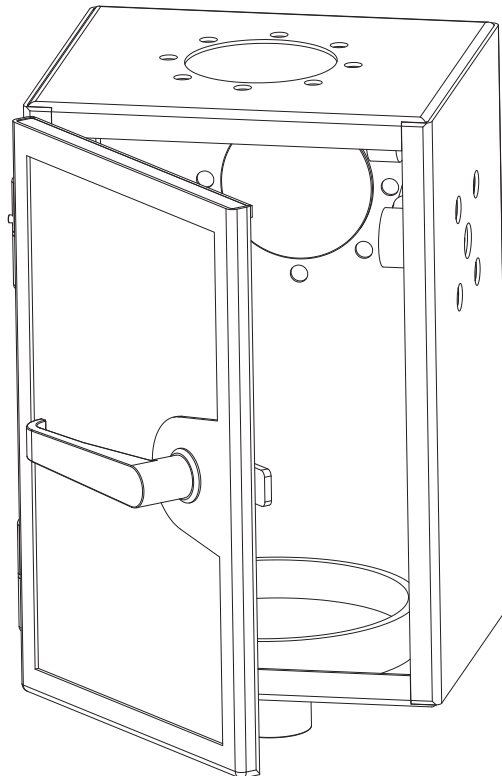
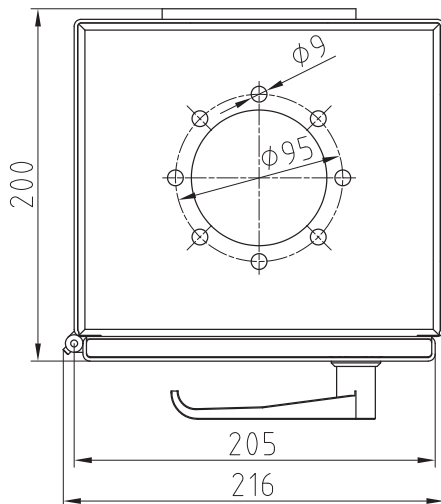
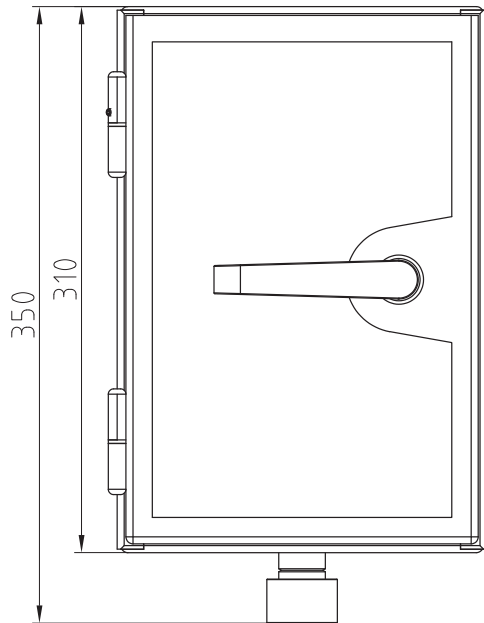

AtoPro Protection Box (Cabinet) - Disassembly Instruction

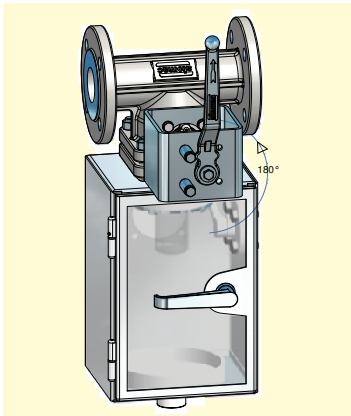

1. Handlever in the upper position (180°)

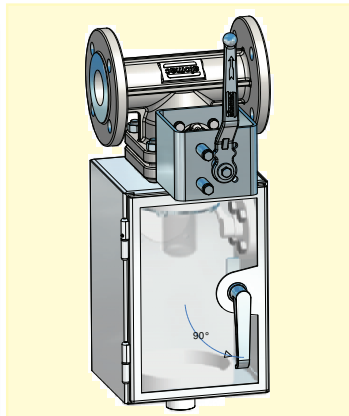

2. Move boxlever 90° counterclockwise

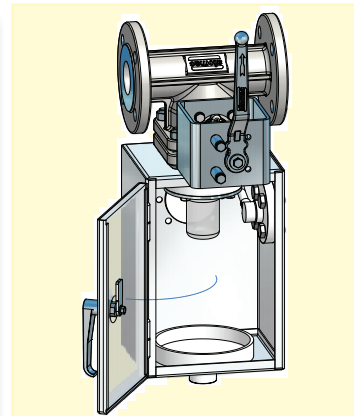

3. Open the door

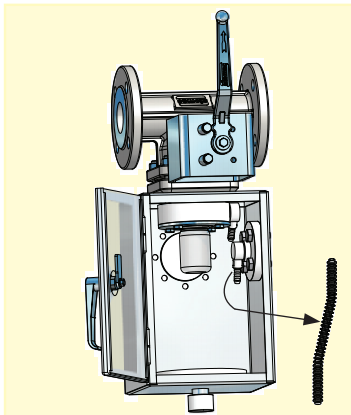

4. Remove heating tube

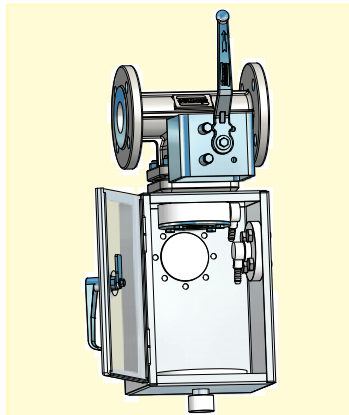

5. Remove bottle

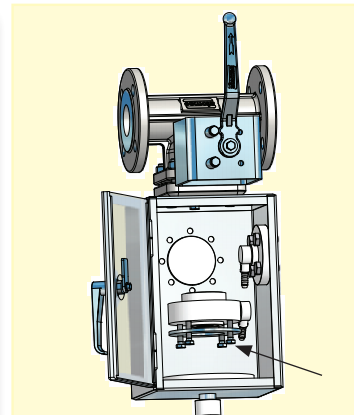

6. Loosen the hexagon screws

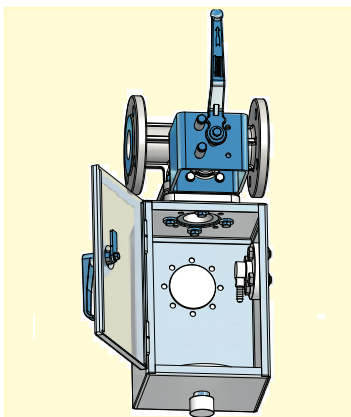

7. Remove adapter and metal plate

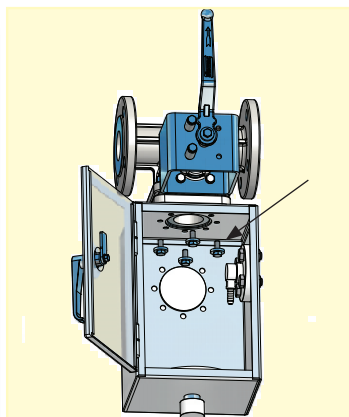

8. Loosen fixing bolts

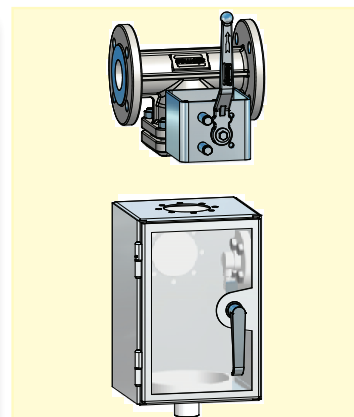

7. Remove Protection Box

Sampling with the AtoPro

1.

Valve in closed position

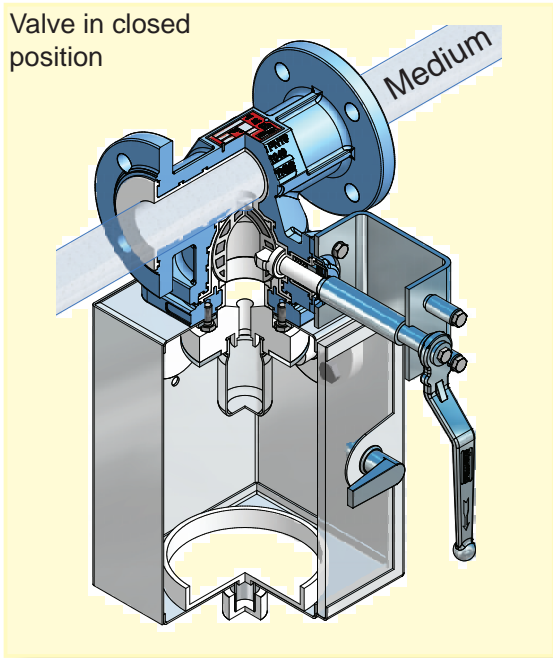

2.

Valve open for sampling

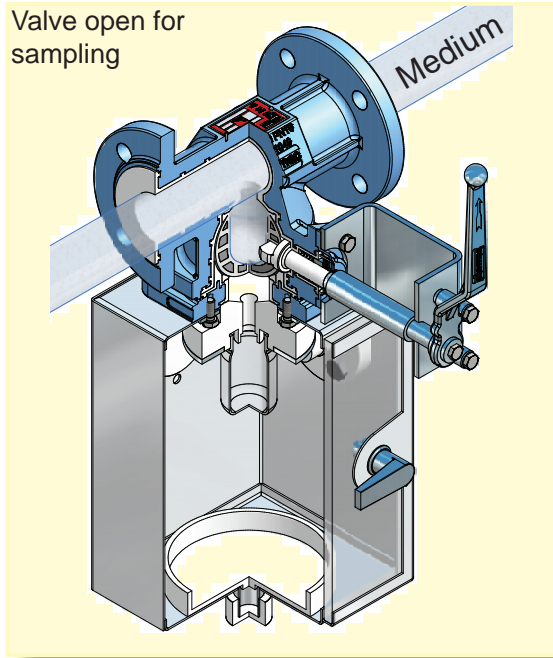

3.

Bottle filling position (180°)

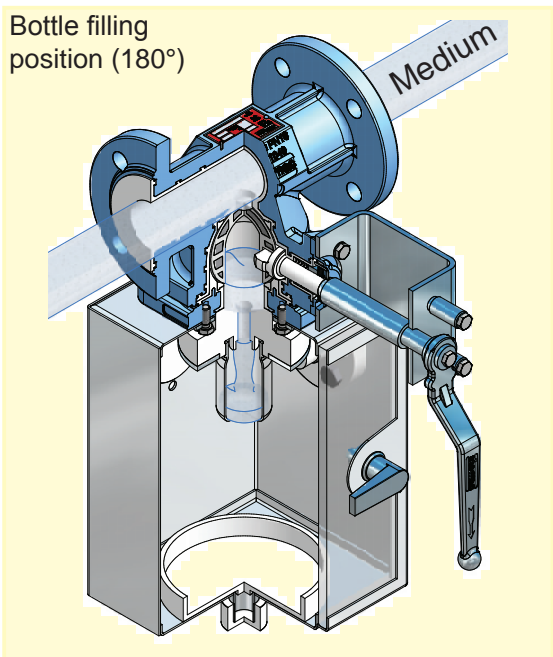

4.

