

Technical Manual

Register: 15
Page: 1
Date: 05.1999
Revision: 06.2020



For further information
please contact CRP Ltd.
Tel. +44(0)1706 756 400
web. www.crp.co.uk
email. enquiry@crp.co.uk

Register 15 CONTENTS - ASG 3

Contents

Technical Data ASG 3-DIN	2
Material Specification ASG 3	3
Dimensions ASG 3-DIN	4
Spare Parts ASG 3	5
Assembly Instructions ASG 3	6
Disassembly Instructions ASG 3	6
ASG 3 - Recommended Tightening Torques	7
Technical Data ASG/B-DIN	8
Material Specification ASG/B	9
ASG/B - Recommended Tightening Torques	9



Technical Data ASG 3

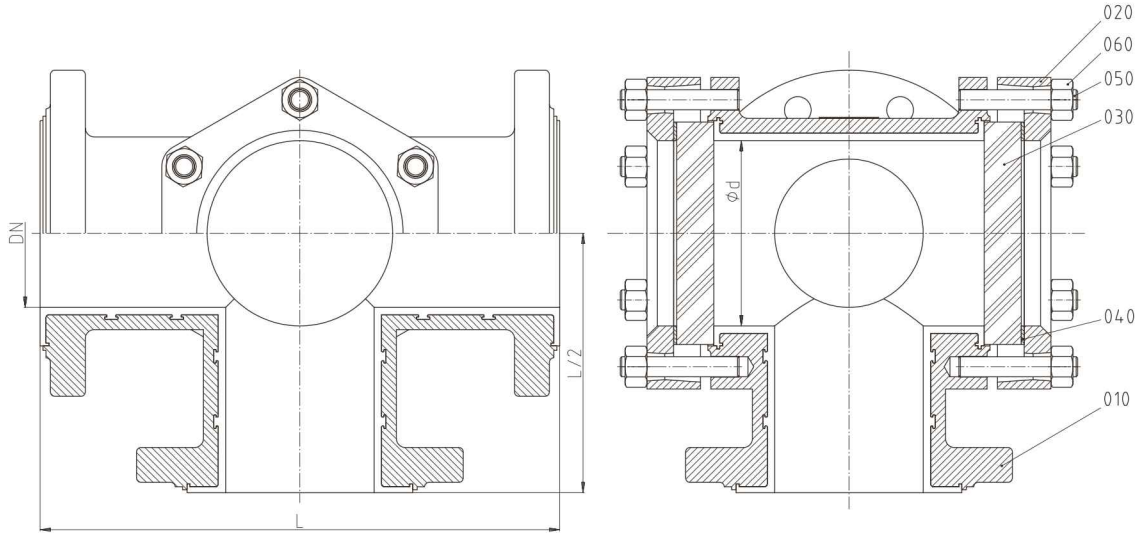

Attention!
 Thermal Shock Resistance of Borosilicate-Glass is according to DIN 7080 t= max. 80°C (176°F). Everything else according to **atomac** Pressure / Temperature Diagram.

Face-to-Face Dimensions: DIN EN 558 (Basic series 1)
 Flange Connections: DIN EN 1092-2 PN 16

DN / DIN		L	L/2	Ød	weight	
025	mm	160	80	45	kg	6,3
	inch	6,3	3,15	1,77	lbs	14,0
050	mm	230	115	77	kg	15,3
	inch	9,06	4,53	3,03	lbs	33,7
080	mm	310	155	100	kg	26,7
	inch	12,2	6,1	3,94	lbs	58,7
100	mm	350	175	125	kg	28,1
	inch	13,78	6,89	4,92	lbs	91,9

Material specification ASG 3

No.	Designation	Pieces	Material	Material-No. / DIN	ASTM / AISI
010	body	1	ductile iron / PFA	EN-JS1049 (GGG-40.3) / DIN EN 1563	A 395
			ductile iron / PFA conductive	EN-JS1049 (GGG-40.3) / DIN EN 1563	A 395
020	flange	2	ductile iron	EN-JS1049 (GGG-40.3) / DIN EN 1563	A 395
030	glass	2	borosilicate-glass	DIN 7080	
040	flat gasket	2	UNITEC 300 green	DIN 3535-6	
050	stud bolt	1 set	stainless steel	1.4301 / DIN EN 10088-3	A 193 B8
060	hexagon nut	1 set	stainless steel	1.4301 / DIN EN 10088-3	A 194 8

Valves with conductive lining only contain components with conductive materials

Dimensions ASG 3

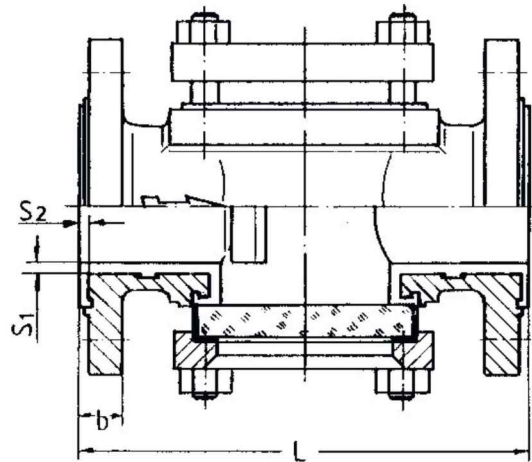
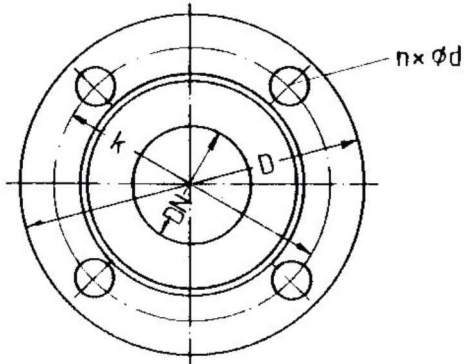

DN / DIN		L	L/2	b	D	k	nxØd	S1	S2
025	mm	160	80	20	115	85	4x14	4	4
	inch	6,3	3,2	0,79	4,53	3,35	4x0,55	0,16	0,16
050	mm	230	115	23	165	125	4x18	4	4
	inch	9,06	4,53	0,91	6,5	4,92	4x0,71	0,16	0,16
080	mm	310	155	25	200	160	8x18	5	4
	inch	12,2	6,1	0,98	7,87	6,3	8x0,71	0,2	0,16
100	mm	350	175	25	220	180	8x18	5	4
	inch	13,78	6,89	0,98	8,66	7,09	8x0,71	0,2	0,16

Spare Parts (item n°) - ASG 3

DIN	Borosilicate glass	flat gasket PTFE
025	0009537	0005257
050	0009539	0005259
080	0009540	0009546
100	0009541	0009184

ASSEMBLY INSTRUCTIONS ASG 3

The general installation and maintenance instructions must be observed.

1. When assembling ASG, special care must be taken that sealing surfaces are absolutely clean and free from any damage.
2. Screw in stud bolts **(050)**.
3. Insert glass **(030)**.
4. Insert gasket **(040)**.
5. Put on flange **(020)**.
6. Put one serrated lock washer **(100)** per flange over a stud bolt and tighten hexagon nuts **(060)** by criss-cross method acc. to recommended torques.

DISASSEMBLY INSTRUCTIONS ASG 3

For all jobs which are to be carried out on an installed valve, the works safety requirements and the general installation and maintenance instructions for flour carbon resin lined atomac valves must be observed.

1. Prior to disassembly, the valve must be drained of all line media, acc. to the above-mentioned instructions. After having removed the flange connection, put valve on workbench with a soft cover (rubber mat).
2. Remove hexagon nuts **(060)**.
3. Remove parts as follows:
 - a. flange **(020)**
 - b. gasket **(040)**
 - c. glass **(030)**
4. Remove stud bolts **(050)**.

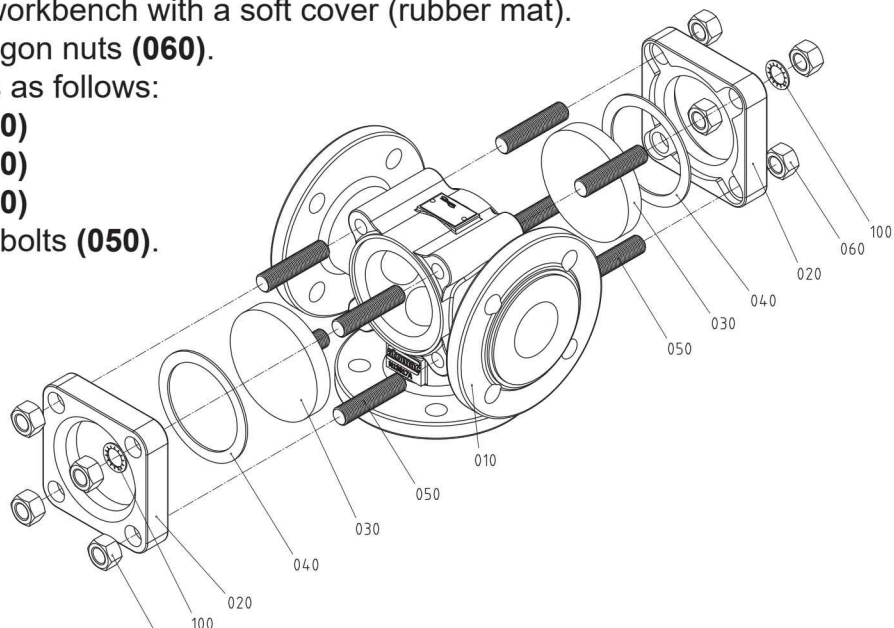

ASG 3 - recommended tightening torques*

DN	tie rods (050/060)		connection flange	
	Nm	lbf · in	Nm	lbf · in
025	14	124	25	221
050	40	195	65	575
080	55	487	55	487
100	47	416	64	566

* max. value

When bolting together dissimilar materials, always tighten to the lowest recommended torque of the components in the joint. Using higher torques may cause excessive deformation of the „softer“ material in the joint

Technical Data ASG/B

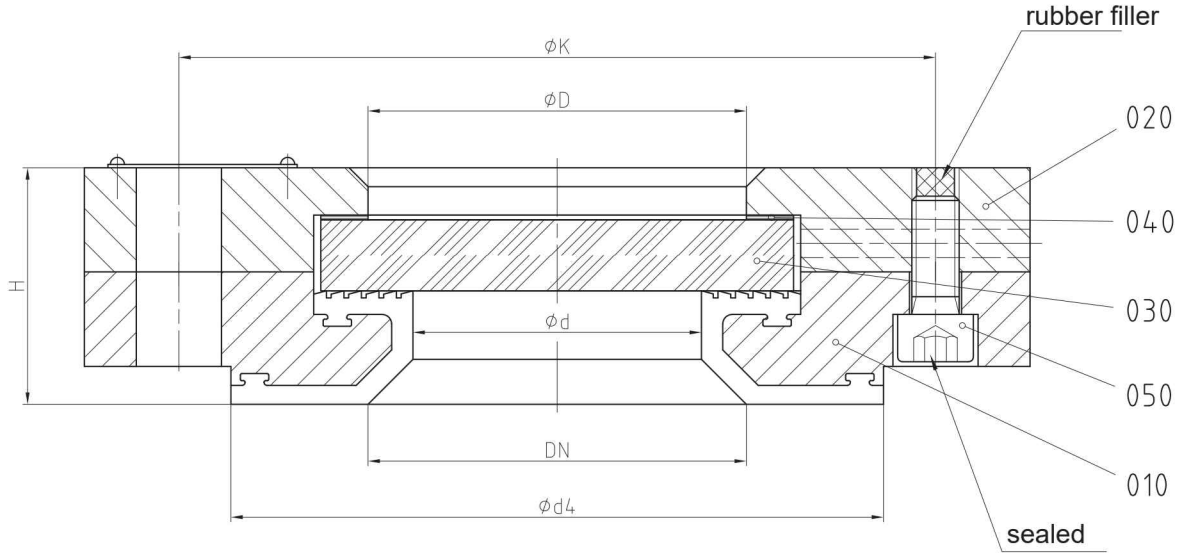

„DBGM“

Max. allowed overpressure 145 psi DIN 28121
 Flange Connections DIN EN 1092-2 PN 10

DN / DIN		H	ØD	Ød	Ød4	ØK		
080	mm	50	80	61	138	160	kg	8,2
	inch	1,97	3,15	2,4	5,43	6,3	lbs	18,1
100	mm	50	100	86	158	180	kg	11,0
	inch	1,97	3,94	3,39	6,22	7,09	lbs	24,3
125	mm	58	125	110	188	210	kg	15,7
	inch	2,28	4,92	4,33	7,4	8,27	lbs	34,7
150	mm	58	125	110	212	240	kg	19,0
	inch	2,28	4,92	4,33	8,35	9,45	lbs	41,9
200	mm	58	150	135	268	295	kg	33,0
	inch	2,28	5,91	5,31	10,55	11,61	lbs	72,8

Material specification ASG/B

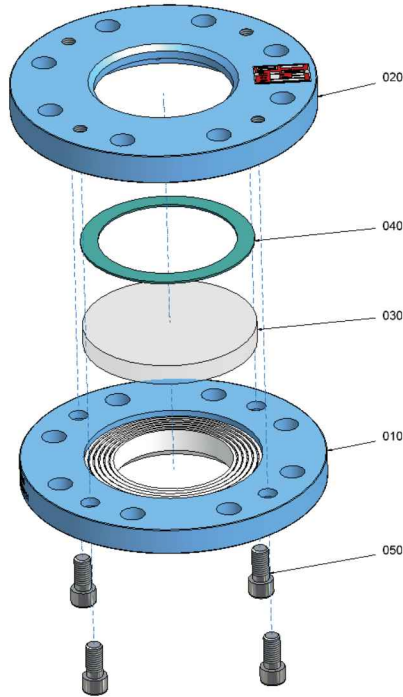

No.	Designation	Pieces	Material	Material-No. / DIN	ASTM / AISI
010	basic flange	1	steel / PFA	1.0038 DIN EN 10025-2	A 283-78
020	counter flange	1	steel	1.0038 DIN EN 10025-2	A 283-78
030	glass	1	borosilicate-glass	DIN 7080	
040	flat gasket	1	UNITEC 300 green	DIN 3535-6	
050	hexagonal socket head	4	steel	8.8 / DIN EN ISO 4762	

ASG/B - recommended tightening torques

DN	Nm
80	55
100	67
125	90
150	130
200	190