



For further information  
please contact CRP Ltd.  
Tel. +44(0)1706 756 400  
web. [www.crp.co.uk](http://www.crp.co.uk)  
email. [enquiry@crp.co.uk](mailto:enquiry@crp.co.uk)

## Register 6 CONTENTS - AKH6

### Contents

<i>Technical Data AKH6 (DIN)</i> .....	2
<i>Technical Data AKH6 (ANSI)</i> .....	3
<i>Material specification AKH6</i> .....	4
<i>Dimensions AKH6 (DIN)</i> .....	5
<i>Dimensions AKH6 (ANSI)</i> .....	6
<i>Spare Parts (item n°) - AKH6 Standard Version</i> .....	7
<i>Assembly Instructions AKH6</i> .....	8
<i>Disassembly Instructions for AKH6</i> .....	9
<i>AKH6 - recommended tightening torques*</i> .....	10
<i>Gear Operator (worm gear)</i> .....	11
<i>Material specification - AKH6 with manual Gear</i> .....	12
<i>AKH6 - Actuator Sizing Torques</i> .....	13
<i>AKH6 with kit for actuator mounting</i> .....	14
<i>AKH6 - Dimension for actuator mounting acc. to NAMUR - recommendation</i> ....	15
<i>AKH6/DA with pressure compensation grooves by slotted seat ring</i> .....	16
<i>Special cleaning and packaging procedures</i> .....	17
<i>AKH6 Extension Kit</i> .....	17
<i>AKH6 - <math>K_v</math> Data and <math>C_v</math> Data (DIN EN 60534-2-3)</i> .....	18
<i>Optional ball with side vent hole</i> .....	19
<i>Optional with C-ball</i> .....	20
<i>Optional with V-ball or S-ball</i> .....	21

## Technical Data AKH6 (DIN)

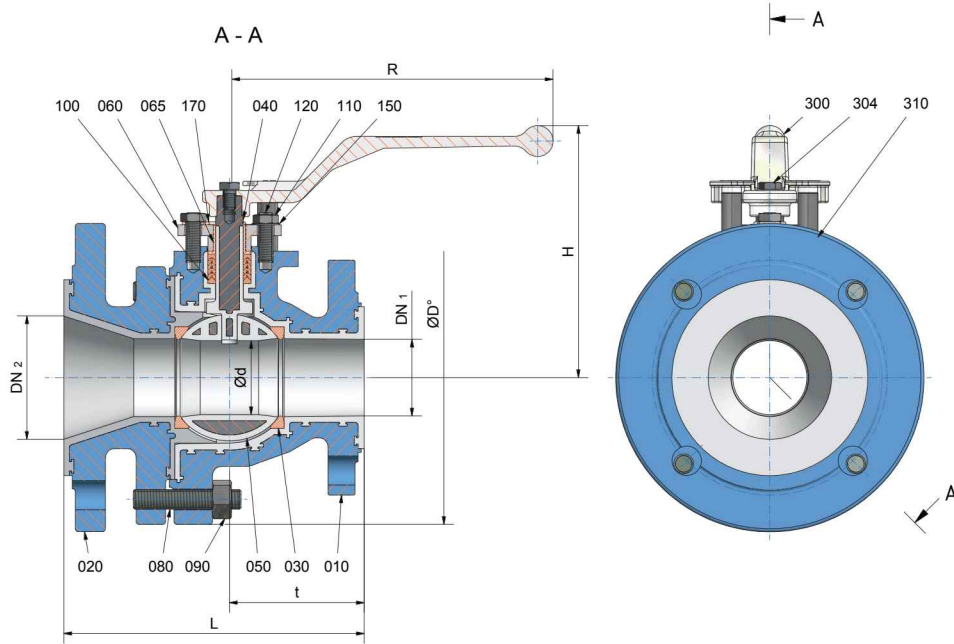

Flange Connections DIN EN 1092-2 PN 16  
 DN 200 DIN EN 1092-2 PN 10

DN1 / DN2		L	H	R	t	ØD°	Ød	weight	
<b>025/050</b>	mm	150	124	160	65,5	106	24	kg	7,6
	inch	5,91	4,88	6,3	2,58	4,17	0,94	lbs	16,8
<b>025/100</b>	mm	150	124	160	65,5	106	24	kg	10,7
	inch	5,91	4,88	6,3	2,58	4,17	0,94	lbs	23,6
<b>040/080</b>	mm	185	150	210	80	124	38	kg	10,7
	inch	7,28	5,91	8,27	3,15	4,88	1,5	lbs	23,6
<b>050/080</b>	mm	195	165,5	210	87,5	144	48	kg	17,7
	inch	7,68	6,52	8,27	3,44	5,67	1,89	lbs	39,0
<b>050/100</b>	mm	200	165,5	210	87,5	144	48	kg	19,8
	inch	7,87	6,52	8,27	3,44	5,67	1,89	lbs	43,7
<b>050/150</b>	mm	185	165,5	210	87,5	144	48	kg	22,6
	inch	7,28	6,52	8,27	3,44	5,67	1,89	lbs	49,8
<b>080/100</b>	mm	245	212	313	118	230	80	kg	39,0
	inch	9,65	8,35	12,32	4,65	9,06	3,15	lbs	86,0
<b>080/150</b>	mm	280	212	313	118	230	80	kg	37,8
	inch	11,02	8,35	12,32	4,65	9,06	3,15	lbs	83,3
<b>100/150</b>	mm	290	227	313	140	250	100	kg	52,0
	inch	11,42	8,94	12,32	5,51	9,84	3,94	lbs	114,6
<b>150/200</b>	mm	305	317	337*	180	365	147	kg	90,0
	inch	12	12,48	13,27*	7,09	14,37	5,79	lbs	198,4
<b>150/250</b>	mm	350	317	337*	180	395	147	kg	211,0
	inch	13,78	12,48	13,27*	7,09	15,55	5,79	lbs	465,2

\* pass-through handlever ø 26,54 inch  
 ° DN 025-050 quadrilateral, DN 080 octagonal, DN 100 hexagonal

**Technical Data AKH6 (ANSI)**

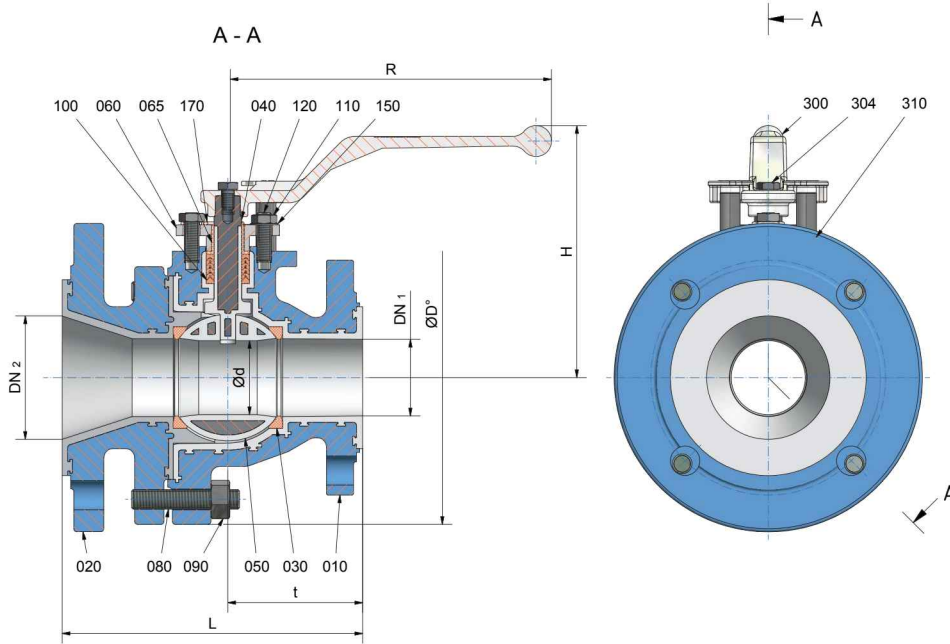

Flange Connections ASME B 16.5 Cass 150,  
 Min. flange thickness acc.  
 to ASME B 16.5 Cass 150,  
 Table 9 (Flanged Fittings)

DN1 / DN2	L	H	R	t	ØD°	Ød	weight	
1" / 2"	inch	5,91	4,88	6,3	2,58	4,17	lbs	16,8
	mm	150	124	160	65,5	106	kg	7,6
1 1/2" / 3"	inch	7,28	5,91	8,27	3,15	4,88	lbs	23,6
	mm	185	150	210	80	124	kg	10,7
2" / 3"	inch	7,68	6,52	8,27	3,44	5,67	lbs	37,7
	mm	195	165,5	210	87,5	144	kg	17,1
2" / 4"	inch	7,87	6,52	8,27	3,44	5,67	lbs	43,7
	mm	200	165,5	210	87,5	144	kg	19,8
2" / 6"	inch	7,28	6,52	8,27	3,44	5,67	lbs	48,7
	mm	185	165,5	210	87,5	144	kg	22,1
3" / 4"	inch	9,65	8,35	12,32	4,65	9,06	lbs	82,7
	mm	245	212	313	118	230	kg	37,5
4" / 6"	inch	11,42	8,94	12,32	5,51	9,84	lbs	123,7
	mm	290	227	313	140	250	kg	56,1
6" / 8"	inch	12	12,44	13,27*	5,08	14,37	lbs	198,4
	mm	305	316	337*	129	365	kg	90,0

\* pass-through handle Ø 26,54 inch  
 ° DN 1"-2" quadrilateral, DN 3" octagonal, DN 100 hexagonal

# Technical Manual

## Material specification AKH6

No.	Designation	Quantity	Material	Material-No. / DIN	ASTM / AISI
010	body	1	ductile iron / PFA	EN-JS1049 (GGG-40.3) / DIN EN 1563	A 395
		1	ductile iron / PFA conductive	EN-JS1049 (GGG-40.3) / DIN EN 1563	A 395
020	side piece	1	ductile iron / PFA	EN-JS1049 (GGG-40.3) / DIN EN 1563	A 395
		1	ductile iron / PFA conductive	EN-JS1049 (GGG-40.3) / DIN EN 1563	A 395
030	seat ring	1	DN 150° stainless steel / PFA	1.4571	
		2	PTFE		
040	stem	2	PTFE conductive		
		1	stainless steel / PFA	1.4470 / DIN EN 10283	A 890 CD3MN
050	ball	1	stainless steel / PFA conductive	1.4470 / DIN EN 10283	A 890 CD3MN
		1	Hastelloy C4 / PFA **	2.4610 / DIN 17744	
060	gland follower	1	cast steel / PFA	1.0619 / DIN EN 10213-2	A 216 Grade WCB
		1	cast steel / PFA conductive	1.0619 / DIN EN 10213-2	A 216 Grade WCB
		1	DN 080°-150°, DN 3°-6° ductile iron / PFA	EN-JS1049 (GGG-40.3) / DIN EN 1563	A 395
		1	ductile iron / PFA conductive	EN-JS1049 (GGG-40.3) / DIN EN 1563	A 395
080	stud bolt	1	ceramic Al <sub>2</sub> O <sub>3</sub> *		
		1	stainless steel / PTFE-graphite	1.4308 / DIN EN 10283	A 743 CF-8
090	hexagon nut	1 set	DN 150°, DN 1° - 6° stainless steel	1.4301-K70 / DIN EN 10088-3	A 193 B8
		1 set	DN 025° - 100° stainless steel	1.4301-K70 / DIN EN 10088-3	A 193 B8
100	packing material (chevron)	1 set	stainless steel	1.4301-K70 / DIN EN 10088-3	A 194 8
		1 set	PTFE °		
110	hexagon nut	1 set	PTFE-graphite °		
		2	stainless steel	1.4301 / DIN EN 10088-3	A 194 8
120	stud bolt	2	stainless steel	1.4301 / DIN EN 10088-3	A 193 B8
150	serrated lock washer	1	stainless steel	1.4301 / DIN EN 10088-3	AISI 304
170	grounding device	1	stainless steel	1.4310 / DIN EN 10270-3	AISI 301
300	hand lever	1	DN 025°-100°, 1°-4° die cast metall (galvanized)	ZP0410 / DIN EN 12844	
		1	DN 150°, 6°: adapter; lever	1.4308 / DIN EN 10283; 1.0037 / DIN EN 10025-2	A 743 CF-8; A283 B
		1	steel (chromated)		
304	hexagon bolt	1	stainless steel	1.4301 / DIN EN 10088-3	A 193 B8
310	stop	2	DN 025°-100°, 1°-4° stainless steel	1.4301 / DIN EN 10088-3	AISI 304
		1	DN 150°, DN 6° ^ stainless steel	1.4104 / DIN EN 10088-3	AISI 430 F

Valves with conductive lining only contain components with conductive materials

\* ceramic ball on request (available up to DN 150/200 and DN 6"/8")

\*\* Hastelloy stem on request

° optional

^ DN 150° und 6° 2 hexagon bolts

**Dimensions AKH6 (DIN)**

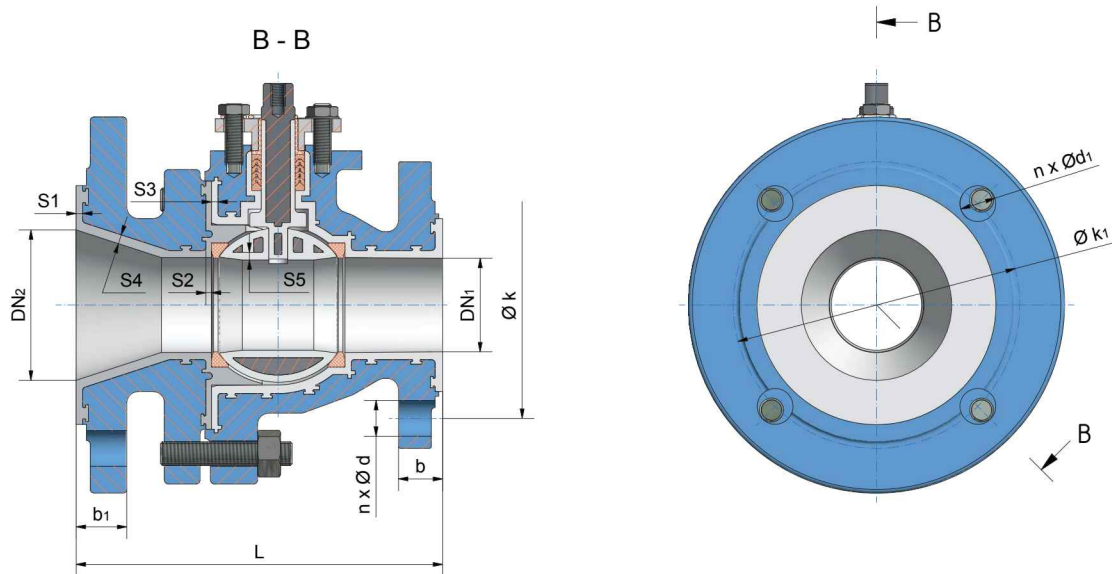

DN1 / DN2	L	b	b1	Øk	Øk1	n x Ød	n x Ød1	S1	S2	S3	S4	S5	
025/050	mm	150	16,5	22	85	125	4 x 14	4 x 18	3,5	2,5	3	3,5	2,5
	inch	5,91	0,65	0,85	3,35	4,92	4 x 0,55	4 x 0,71	0,14	0,1	0,12	0,14	0,09
025/100	mm	150	16,5	31,5	85	180	4 x 14	4 x 18	3,5	2,5	3	3,5	2,5
	inch	5,91	0,65	1,24	3,35	7,09	4 x 0,55	4 x 0,71	0,14	0,1	0,12	0,14	0,09
040/080	mm	185	20	28	110	160	4 x 18	4 x 18	3,5	3	3	4	3
	inch	7,28	0,79	1,1	4,33	6,3	4 x 0,71	4 x 0,71	0,14	0,12	0,12	0,16	0,12
050/080	mm	195	20,5	27	125	160	4 x 18	4 x 18	4	3	3,5	4	3
	inch	7,68	0,81	1,06	4,92	6,3	4 x 0,71	4 x 0,71	0,16	0,12	0,14	0,16	0,12
050/100	mm	200	20,5	31	125	180	4 x 18	4 x 18	4	3	3,5	4	3
	inch	7,87	0,81	1,22	4,92	7,09	4 x 0,71	4 x 0,71	0,16	0,12	0,14	0,16	0,12
050/150	mm	185	20,5	28	125	240	4 x 18	4 x 18	4	3	3,5	4	3
	inch	7,28	0,81	1,10	4,92	9,45	4 x 0,71	4 x 0,71	0,16	0,12	0,14	0,16	0,12
080/100	mm	245	26	31	160	180	8 x 18	8 x 18	4	5	4	4,5	4,25
	inch	9,65	1,02	1,22	6,3	7,09	8 x 0,71	8 x 0,71	0,16	0,2	0,16	0,18	0,17
080/150	mm	280	26	28,5	160	240	8 x 18	8 x 18	4	5	4	4,5	4,25
	inch	11,02	1,02	1,12	6,3	9,45	8 x 0,71	8 x 0,71	0,16	0,2	0,16	0,18	0,17
100/150	mm	290	28	32,5	180	240	8 x 18	8 x 22	4	5	4	5	4,5
	inch	11,42	1,1	1,28	7,09	9,45	8 x 0,71	8 x 0,87	0,16	0,2	0,16	0,2	0,18
150/200	mm	305	29	33	240	295	8 x 22	8 x 22	4	5	4	6	5,5
	inch	12	1,14	1,3	9,45	11,61	8 x 0,87	8 x 0,87	0,16	0,2	0,16	0,24	0,22
150/250	mm	350	29	36,5	240	355	8 x 22	12 x 26	4,5	5	4	6	5,5
	inch	13,78	1,14	1,44	9,45	13,98	8 x 0,87	12 x 1,02	0,18	0,2	0,16	0,24	0,22

stem lining DN 025/050 0,059 inch  
 all other sizes at least 0,098 inch

## Dimensions AKH6 (ANSI)

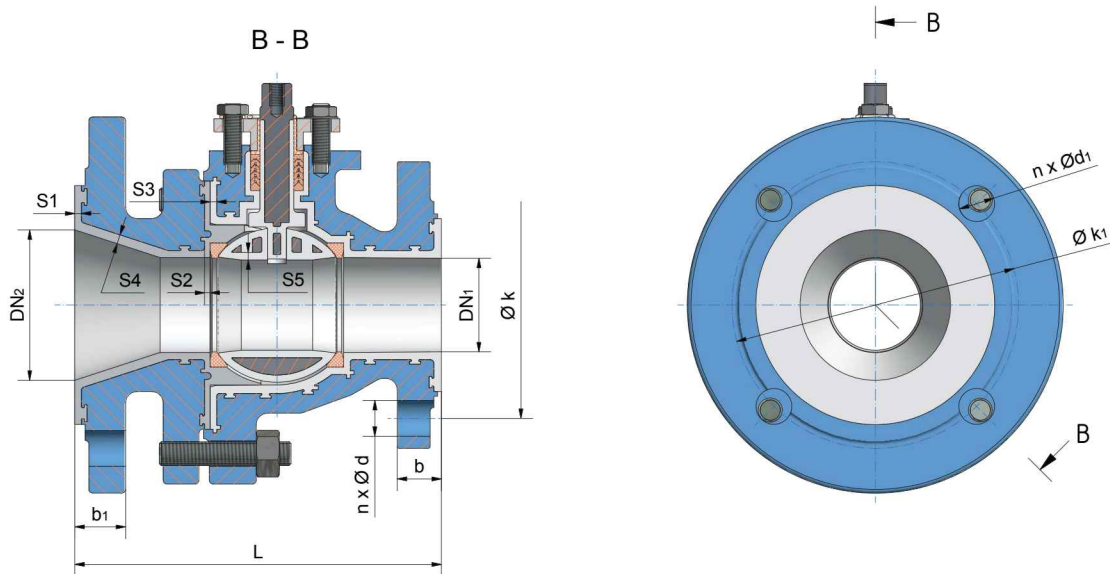

DN1 / DN2	L	b	b1	Øk	Øk1	n x Ød	n x Ød1	S1	S2	S3	S4	S5	
1" / 2"	inch	5,91	0,65	0,85	3,13	4,74	4 x 0,63	4 x 0,75	0,14	0,12	0,12	0,14	0,09
	mm	150	16,5	21,5	79,2	120,5	4 x 16	4 x 19	3,5	3	3	3,5	2,5
1 1/2" / 3"	inch	7,28	0,79	1,02	3,88	6	4 x 0,63	4 x 0,75	0,14	0,12	0,12	0,16	0,12
	mm	185	20	26	98,5	152,5	4 x 16	4 x 19	3,5	3	3	4	3
2" / 3"	inch	7,68	0,81	1,06	4,75	6	4 x 0,75	4 x 0,75	0,16	0,12	0,14	0,16	0,12
	mm	195	20,5	27	120,5	152,5	4 x 19	4 x 19	4	3	4	4	3
2" / 4"	inch	7,78	0,81	1,22	4,75	7,5	4 x 0,75	8 x 0,75	0,16	0,12	0,14	0,16	0,12
	mm	200	20,5	31	120,5	190,5	4 x 19	8 x 19	4	3	4	4	3
2" / 6"	inch	7,28	0,81	1,1	4,75	9,45	4 x 0,75	8 x 0,75	0,16	0,12	0,14	0,16	0,12
	mm	185	20,5	28	120,5	240	4 x 19	8 x 19	4	3	4	4	3
3" / 4"	inch	9,65	1,02	1,22	6	7,5	8 x 0,75	8 x 0,75	0,16	0,2	0,16	0,18	0,17
	mm	245	26	31	152,5	190,5	8 x 19	8 x 19	4	5	4	4,5	4,25
4" / 6"	inch	11,42	1,1	1,28	7,5	9,51	8 x 0,75	8 x 0,87	0,16	0,2	0,16	0,2	0,18
	mm	290	28	32,5	190,5	241,5	8 x 19	8 x 22	4	5	4	5	4,5
6" / 8"	inch	12	1,14	1,3	9,51	11,75	8 x 0,87	8 x 0,87	0,16	0,2	0,16	0,24	0,22
	mm	305	29	33	241,5	298,5	8 x 22	8 x 22	4	5	4	6	5,5

stem lining DN 1" / 2" 0,059 inch  
 all other sizes at least 0,098 inch

## Spare Parts (item n°) - AKH6 Standard Version

DIN	ANSI	Ball		Seat Rings
		PFA	Ceramic <sup>°</sup>	PTFE
025/050	1"/2"	0000323	0002317	0000159
025/100	---	0000323	0002317	0000159
040/080	1 1/2"/3"	0000325	0002319	0000160
050/080	2"/3"	0000326	0002320	0000161
050/100	2"/4"	0000326	0002320	0000161
050/150	2"/6"	0000326	0002320	0000161
080/100	3"/4"	0000328	0002322	0000163
080/150	--	0000328	0002322	0000163
100/150	4"/6"	0000329	0002323	0000164
150/200	6"/8"	0000330	0002405	0000165
150/250	--	0000330	0002405	0000165

DIN	ANSI	Stem		Packing (set)	
		Stainless Steel/PFA	Hastelloy / PFA	PTFE	PTFE / Graphite
025/050	1"/2"	0000115	0000116	0000167	0000174
025/100	---	0000115	0000116	0000167	0000174
040/080	1 1/2"/3"	0000117	0000118	0000168	0000175
050/080	2"/3"	0000119	0000120	0000169	0000176
050/100	2"/4"	0000119	0000120	0000169	0000176
050/150	2"/6"	0000119	0000120	0000169	0000176
080/100	3"/4"	0000121	0000122	0000170	0000177
080/150	--	0000121	0000122	0000170	0000177
100/150	4"/6"	0000121	0000122	0000170	0000177
150/200	6"/8"	0000123	0000124	0000172	0000179
150/250	--	0000123	0000124	0000172	0000179

<sup>°</sup> Al<sub>2</sub>O<sub>3</sub>

## Assembly Instructions AKH6

*The general installation and maintenance instructions must be observed.*

1. Screw stud bolts (120) into body (010).
2. Insert stem (040) from inside of body in such a way that the flat side is parallel to body longitudinal axis.
3. Insert chevron packing (100).
4. Install gland insert (065), gland follower (060), safety washer (150), hexagon nuts (110) and grounding strap (170).
5. Install hand lever (300) on to stem (040) with the hexagon bolt (304).
6. Insert first seat ring (030) into body (010).
7. Insert ball (050) to valve stem by pushing the ball in a downward motion through valve body.
8. Turn hand lever (300) 90° of longitudinal axis of body.
9. Install second ball seat ring (030) on to ball (050).
10. Install side piece (020) on to body (010), making sure that recess for stem is on the correct side.
11. Install body bolts (080) and hexagon nuts (090) and tighten by crisscross method to recommended torques.
12. Assemble the two stops (310).

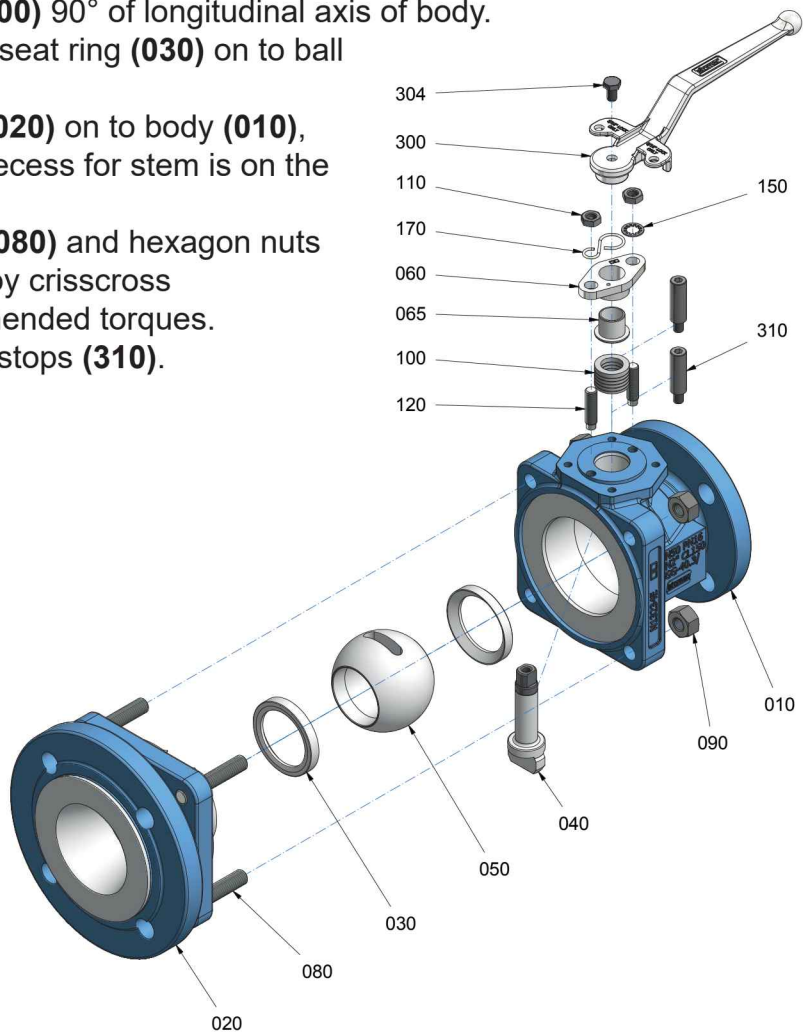



## Disassembly Instructions for AKH6

*For all jobs which are to be carried out on an installed valve, the works safety requirements and the general accident prevention instructions must be observed. Moreover, the general installation and maintenance instructions for atomac fluorocarbon resin lined valves must be considered.*

1. Prior to disassembly, the valve must be cleared of all fluid according to the above-mentioned instructions. Particular care must be taken that during rinsing and draining of the piping, the valve is opened and closed repeatedly. These cycles (opening and closing) are to be repeated during draining of the piping. Only when following this procedure, is it ensured that all remaining pressure inside the body (stem guide and ball seats) is eliminated.
2. For disassembly of the valve, put body on a work bench with a soft cover (rubber mat). If necessary, remove the stops (310). Remove hexagon bolt (110) and lock washer (150) and grounding device (170).
3. Open valve completely. Remove hand lever (300).
4. Disassemble gland follower (060) and gland insert (065). If necessary, stud bolts (120) can also be removed now.
5. Remove body bolts (080) and separate side piece from body.
6. Remove first ball seat ring (030).
7. Put ball in closed position and push ball out of the body.
8. Remove stem (040) by pushing it down through the body (010). Care must be taken not to damage body liner.
9. Chevron packing (100) can easily be removed.

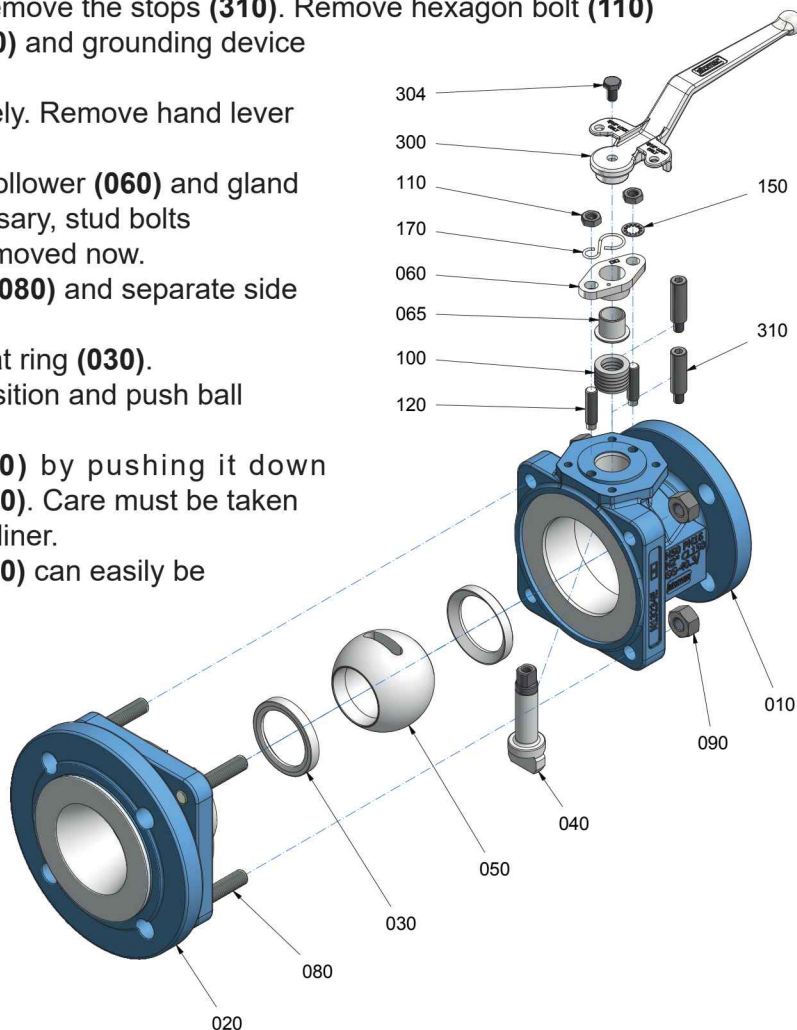

# Technical Manual

## AKH6 - recommended tightening torques\*

DN	tie rods (080/090)		connection flange				gland bolts (110/120/150)	
	Nm	lbf · in	DN1		DN2		Nm	lbf · in
			Nm	lbf · in	Nm	lbf · in		
025/050	26	230	25	221	65	575	4	35
1" / 2"	26	230	15	133	60	531	4	35
025/100	26	230	25	221	65	575	4	35
040/080	54	478	50	442	55	486	7	62
1 1/2" / 3"	59	522	26	257	100	885	7	62
050/080	80	708	65	575	55	486	7	62
2" / 3"	87	770	60	531	100	885	7	62
050/100	80	708	65	575	65	575	7	62
2" / 4"	87	770	60	531	76	673	7	62
050/150	80	708	65	575	130	1150	7	62
2" / 6"	87	770	60	531	129	1142	7	62
080/100	84	743	55	486	65	575	8	71
3" / 4"	87	770	100	885	76	673	8	71
080/150	84	743	55	486	130	1150	8	71
100/150	138	1221	65	575	130	1150	8	71
4" / 6"	143	1266	76	673	129	1142	8	71
150/200	178	1575	130	1150	190	1681	12	106
6" / 8"	180	1593	129	1042	188	1664	12	106
150/250	178	1575	130	1150	232	2053	12	106

\* maximum value

When bolting together dissimilar materials, always tighten to the lowest recommended torque of the components in the joint. Using higher torques may cause excessive deformation of the „softer“ material in the joint

## **Gear Operator** (worm gear)

The fully closed, waterproof actuator consists of a body with lid, worm gear, input shaft and hand wheel. For the correct adjustment of the ball position, there are two adjustable stops mounted in the body.

The gear is fully greased and does not need any further lubrication.

The actuator with hand wheel is mounted on a bracket with four stainless steel bolts. The on/off position is indicated through a pointer. The actuator is self-locked.

<b>Designation</b>	<b>Material</b>
Body	Gray Iron
Worm	Spheroidal Graphite Cast Iron
Input Shaft	AISI 410
Hand Wheel	Steel

**Material specification - AKH6 with manual Gear**

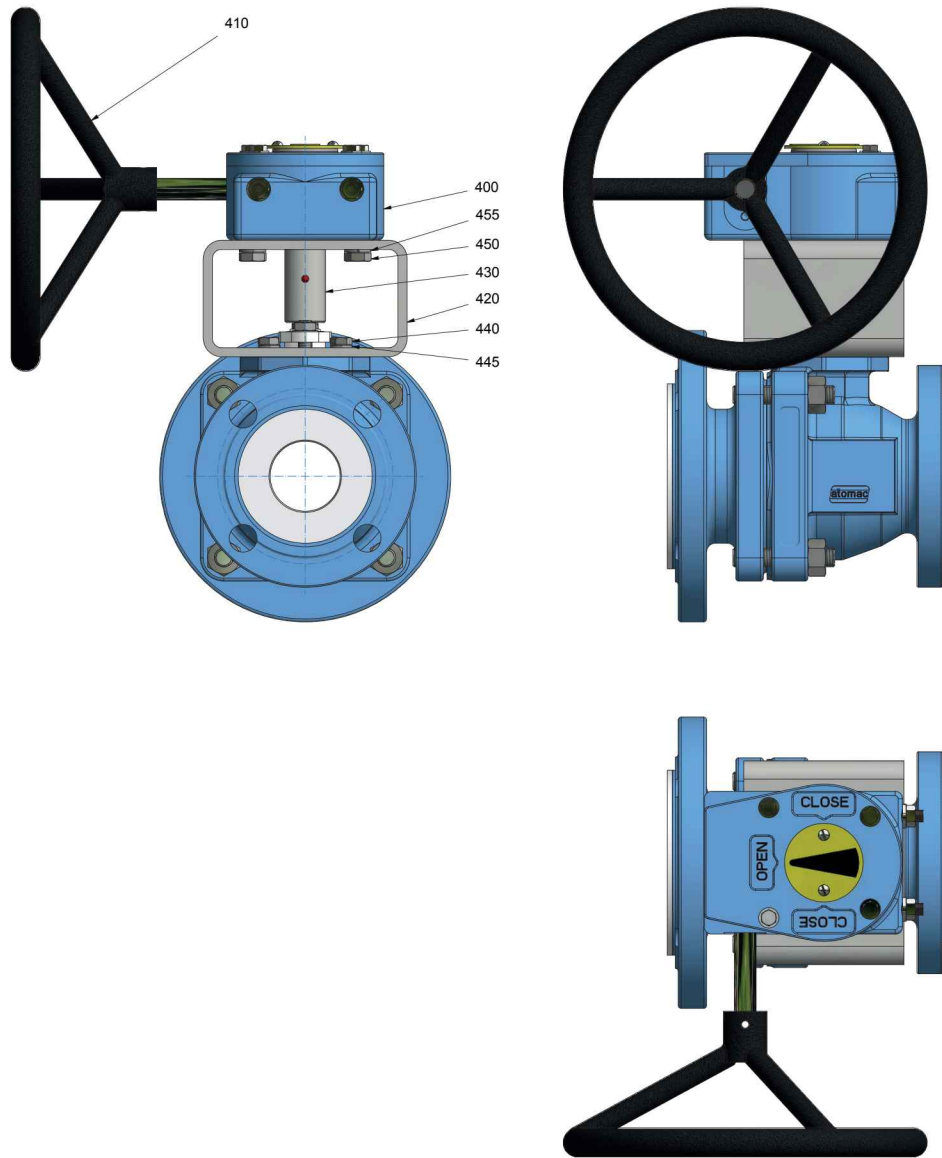

No.	Designation	Quantity	Material	Material-No.	DIN	ASTM / AISI
400	gear	1				
410	handwheel	1				
420	bracket	1	steel (yellow chromated)	1.0037	DIN EN 10025-2	A 283 B
430	adapter	1	stainless steel	1.4104	DIN EN 10088-3	AISI 430 F
440	hexagon bolt	4	stainless steel	1.4301	DIN EN 10088-3	A 193 B8
445	serrated lock washer	4	stainless steel	1.4301	DIN EN 10088-3	AISI 304
450	hexagon bolt	4	stainless steel	1.4301	DIN EN 10088-3	A 193 B8
455	serrated lock washer	4	stainless steel	1.4301	DIN EN 10088-3	AISI 304

## AKH6 - Actuator Sizing Torques

Packingmaterial: chevron PTFE or PTFE-graphite

- for clean and clear application

Size	0 bar Δ p Nm	0 psi Δ p lbf · in	10 bar Δ p Nm	150 psi Δ p lbf · in	19 bar Δ p Nm	275 psi Δ p lbf · in	MAST	
							Nm	lbf · in
025/050 1"/2"	7	62	8	71	8	71	40	354
025/100 ---	7	62	8	71	8	71	40	354
040/080 1 1/2"/3"	20	177	27	239	34	301	115	1018
050/080 2"/3"	27	239	34	301	45	398	130	1151
050/100 2"/4"	27	239	34	301	45	398	130	1151
050/150 2"/6"	27	239	34	301	45	398	130	1151
080/100 3"/4"	59	522	85	752	108	956	420	3717
080/150 ---	59	522	85	752	108	956	420	3717
100/150 4"/6"	79	699	119	1053	158	1398	420	3717
150/200 6"/8"	210	1859	300	2655	360	3186	1107	9798
150/250 ---	210	1859	300	2655	360	3186	1107	9798

- for dry and slurry application

Size	0 bar Δ p Nm	0 psi Δ p lbf · in	10 bar Δ p Nm	150 psi Δ p lbf · in	19 bar Δ p Nm	275 psi Δ p lbf · in	MAST	
							Nm	lbf · in
025/050 1"/2"	9	81	10	92	10	92	40	354
025/100 ---	9	81	10	92	10	92	40	354
040/080 1 1/2"/3"	26	230	35	311	44	391	115	1018
050/080 2"/3"	35	311	44	391	59	518	130	1151
050/100 2"/4"	35	311	44	391	59	518	130	1151
050/150 2"/6"	35	311	44	391	59	518	130	1151
080/100 3"/4"	77	679	111	978	140	1243	420	3717
080/150 ---	77	679	111	978	140	1243	420	3717
100/150 4"/6"	103	909	155	1369	205	1818	420	3717
150/200 6"/8"	273	2416	390	3452	468	4142	1107	9798
150/250 ---	273	2416	390	3452	468	4142	1107	9798

- Stated torques are sizing torques. No further safety factors are to be applied against these torques.
- The use of ceramic balls in lined valves will result in 15% higher sizing torques.
- The use of C-Balls or V-Balls does not result in change in sizing torques.
- Stated sizing torques are „Break-Open“ and „Re-Seating“ torques. Running torques are typically 35% below sizing torques.
- The stated „MAST“ value is the Maximum Allowable Stem Torque. Beyond this value permanent deformation / destruction of liner is to be expected.
- Please note the service conditions of the pressure- / vacuum-temperature-diagrams: register 1, page 13.



## AKH6 with kit for actuator mounting

No.	Designation	Quantity	Material	Material-No.	DIN	ASTM / AISI
500	bracket	1	steel (yellow chromated)	1.0037	DIN EN 10025-2	A 283-B
510	adapter	1	stainless steel	1.4101	DIN EN 10088-3	AISI 430 F
520	hexagon bolt	4	stainless steel	1.4301	DIN EN 10088-3	A 193 B8
525	serrated lock washer	4	stainless steel	1.4301	DIN EN 10088-3	AISI 304
530	hexagon bolt	1 set	stainless steel	1.4301	DIN EN 10088-3	A 193 B8
535	serrated lock washer	1 set	stainless steel	1.4301	DIN EN 10088-3	AISI 304

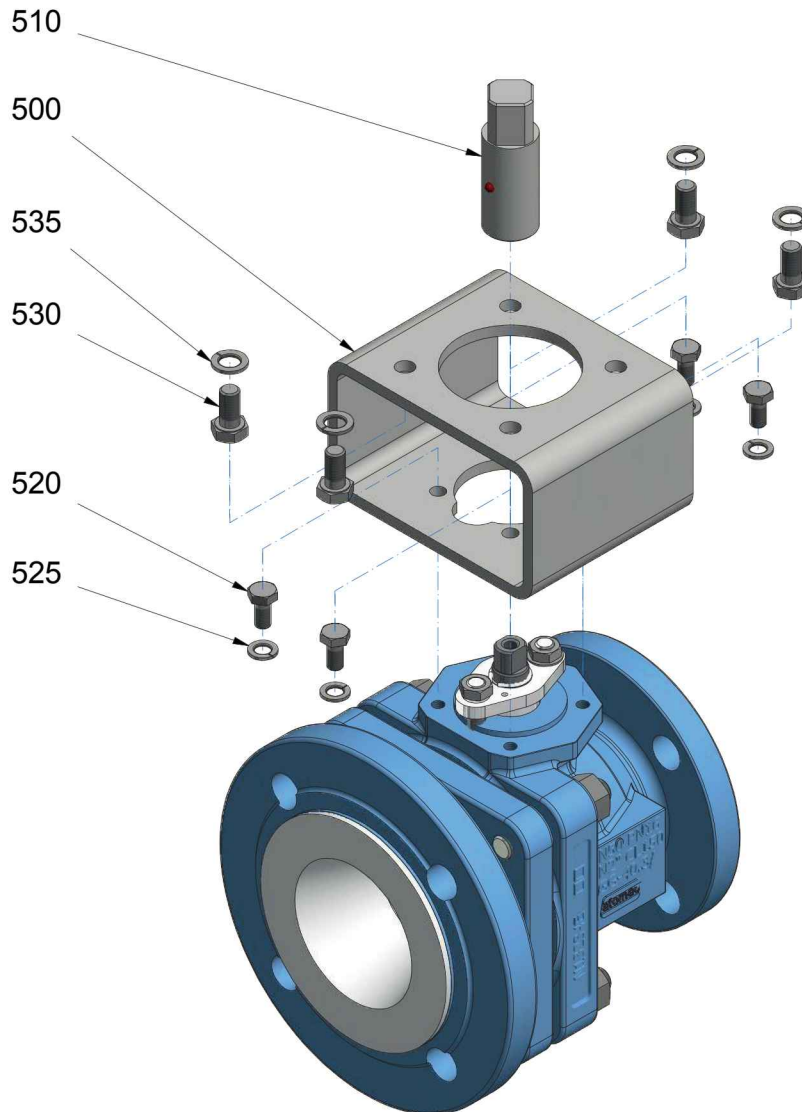

**AKH6 - Dimension for actuator mounting acc. to NAMUR - recommendation**

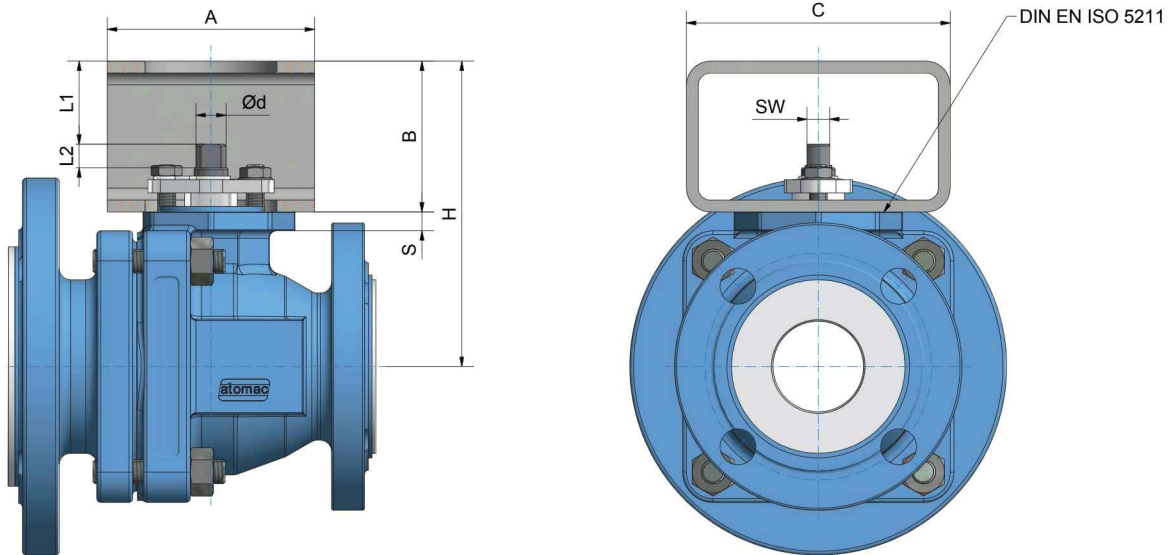

DN1 / DN2		H	A	B	C	SW <sup>+0,1 -0,1</sup>	Ød <sup>+0 -0,1</sup>	S	L1	L2	DIN EN ISO 5211 ISO 5211
025/050 1"/2"	mm	109	75	60	100	8	10	7,5	30,5	9,3	F05
	inch	4,29	2,95	2,36	3,94	0,315	0,393	0,3	1,2	0,37	
025/100 ---	mm	109	75	60	100	8	10	7,5	30,5	9,3	F05
	inch	4,29	2,95	2,36	3,94	0,315	0,393	0,3	1,2	0,37	
040/080 1 1/2"/3"	mm	129	100	60	100	12	16	10	25,5	12,5	F07
	inch	5,05	3,94	2,36	3,94	0,472	0,63	0,39	1	0,49	
050/080 2"/3"	mm	142	100	60	100	12	16	10	23	12,5	F07
	inch	5,59	3,94	2,36	3,94	0,472	0,63	0,39	0,91	0,49	
050/100 2 1/4"	mm	142	100	60	100	12	16	10	23	12,5	F07
	inch	5,59	3,94	2,36	3,94	0,472	0,63	0,39	0,91	0,49	
050/150 2 1/2"/6"	mm	142	100	60	100	12	16	10	23	12,5	F07
	inch	5,59	3,94	2,36	3,94	0,472	0,63	0,39	0,91	0,49	
080/100 3 1/4"	mm	207	135	80	140	16	22	13	34	15,5	F10
	inch	8,15	5,31	3,15	5,51	0,63	0,866	0,51	1,34	0,61	
080/150 ---	mm	207	135	80	140	16	22	13	34	15,5	F10
	inch	8,15	5,31	3,15	5,51	0,63	0,866	0,51	1,34	0,61	
100/150 4 1/2"/6"	mm	222	135	80	140	16	22	13	34	15,5	F10
	inch	8,74	5,31	3,15	5,51	0,63	0,866	0,51	1,34	0,61	
150/200 6 1/2"/8"	mm	284	135	80	140	20	30	14	23	19,5	F12
	inch	11,18	5,31	3,15	5,51	0,787	1,181	0,55	0,91	0,77	
150/250 ---	mm	284	135	80	140	20	30	14	23	19,5	F12
	inch	11,18	5,31	3,15	5,51	0,79	1,181	0,55	0,91	0,77	

## AKH6/DA with pressure compensation grooves by slotted seat ring

See material specification AKH6 page 4.

No.	Designation	Quantity	Material	Material-No. / DIN	ASTM / AISI
035	seat ring with pressure compensation grooves	1	PTFE	pure - PTFE	

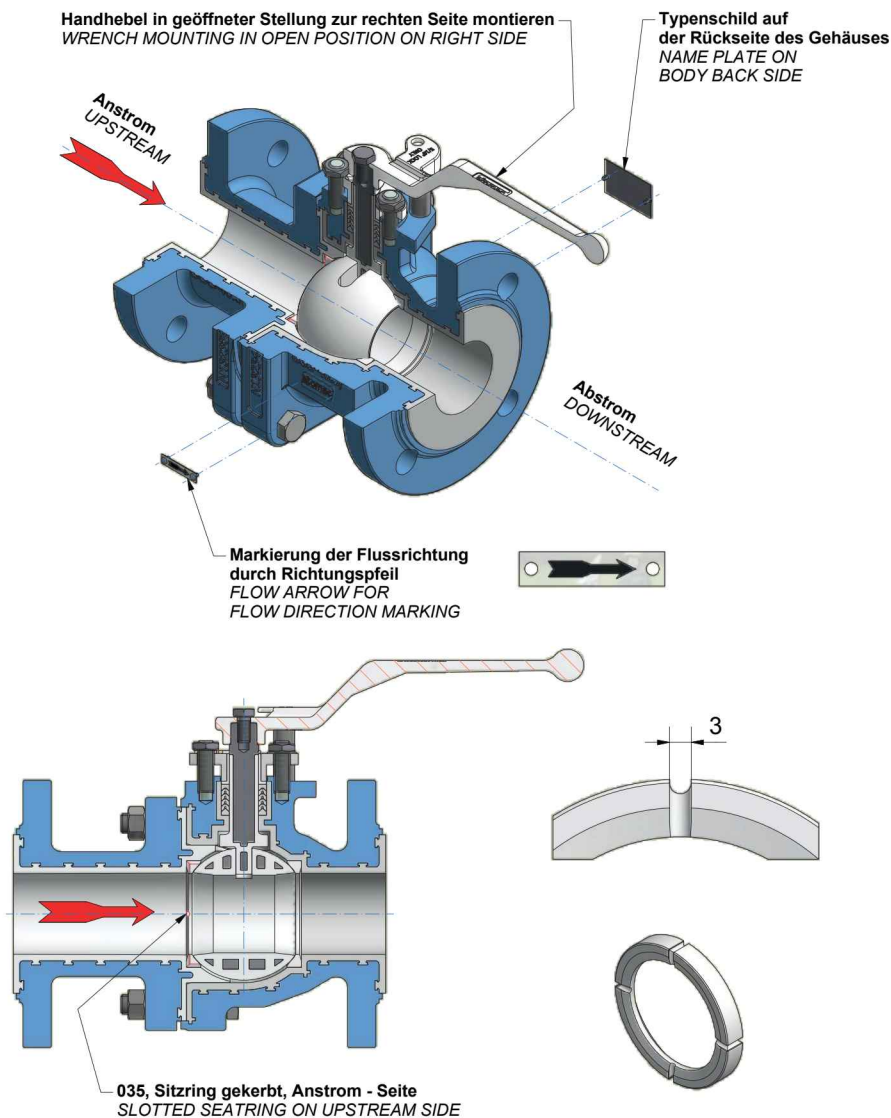

See Assembly Instructions AKH6 page 8.

**Attention, please take care of the tight direction of indicator while assembly.**

9. Install ball seat ring with pressure compensation grooves (035) on to ball (050).  
 Disassembly instruction see AKH6 page 9



## Special cleaning and packaging procedures

### 1. Recleaning

The ball valve should be thoroughly cleaned with a clean, dry, lint-free towel and blown off with dry nitrogen gas. This will assure that the valve is free from moisture, grease and other media before packing.

### 2. Packing

Prior to packing, the ball valve should be jig welded in a PE-foil (0.2 mm thick). The bag contains desiccants acc. to DIN 55473, quantity acc. to DIN 55474 and a moisture indicator.

## AKH6 Extension Kit

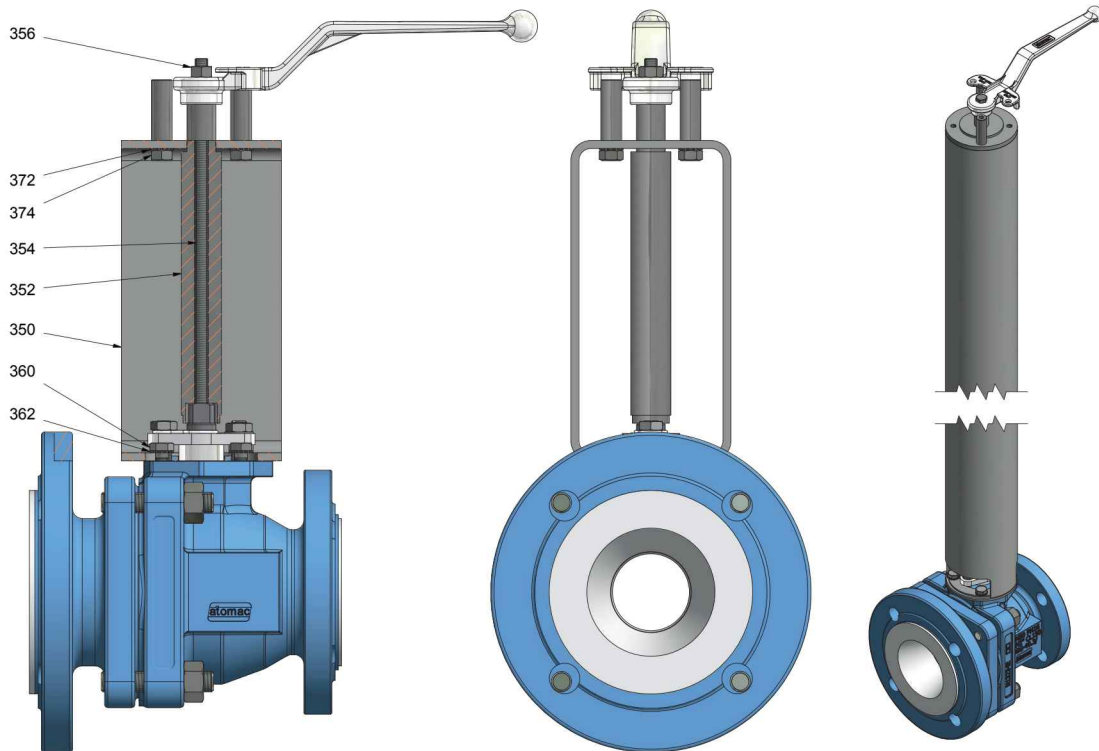

No.	Designation	Pieces	Material	Material-No.	DIN	ASTM / AISI
350	bracket	1	steel, yellow chromated	1.0037	DIN EN 10025-2	A 283 B
352	adapter	1	stainless steel	1.4104	DIN EN 10088-3	AISI 430 F
354	stud bolt	1	stainless steel	1.4301	DIN EN 10088-3	A 193 B8
356	hexagon nut	1	stainless steel	1.4301	DIN EN 10088-3	A 194 8
360	hexagon bolt	2	stainless steel	1.4301	DIN EN 10088-3	A 193 B8
362	serrated lock washer	2	stainless steel	1.4301	DIN EN 10088-3	AISI 304
372	serrated lock washer	2	stainless steel	1.4301	DIN EN 10088-3	AISI 304
374	hexagon nut	2	stainless steel	1.4301	DIN EN 10088-3	A 194 8

**AKH6 -  $K_v$  Data and  $C_v$  Data (DIN EN 60534-2-3)**

DIN	ANSI	$K_v$ m <sup>3</sup> /h	$C_v$ gal/min
025/050	1"/2"	32,1	37,3
025/100	---	30,0*	34,9*
040/080	1½"/3"	116,3	135,2
050/080	2"/3"	69,4	80,7
050/100	2"/4"	66,7	77,5
050/150	2"/6"	60,5*	70,3*
080/100	3"/4"	574,3	667,5
080/150	---	550,0*	639,3*
100/150	4"/6"	287,1	333,7
150/200	6"/8"	1195,0*	1388,9*
150/250	---	- at the moment not available -	

\* estimated value

## Optional ball with side vent hole

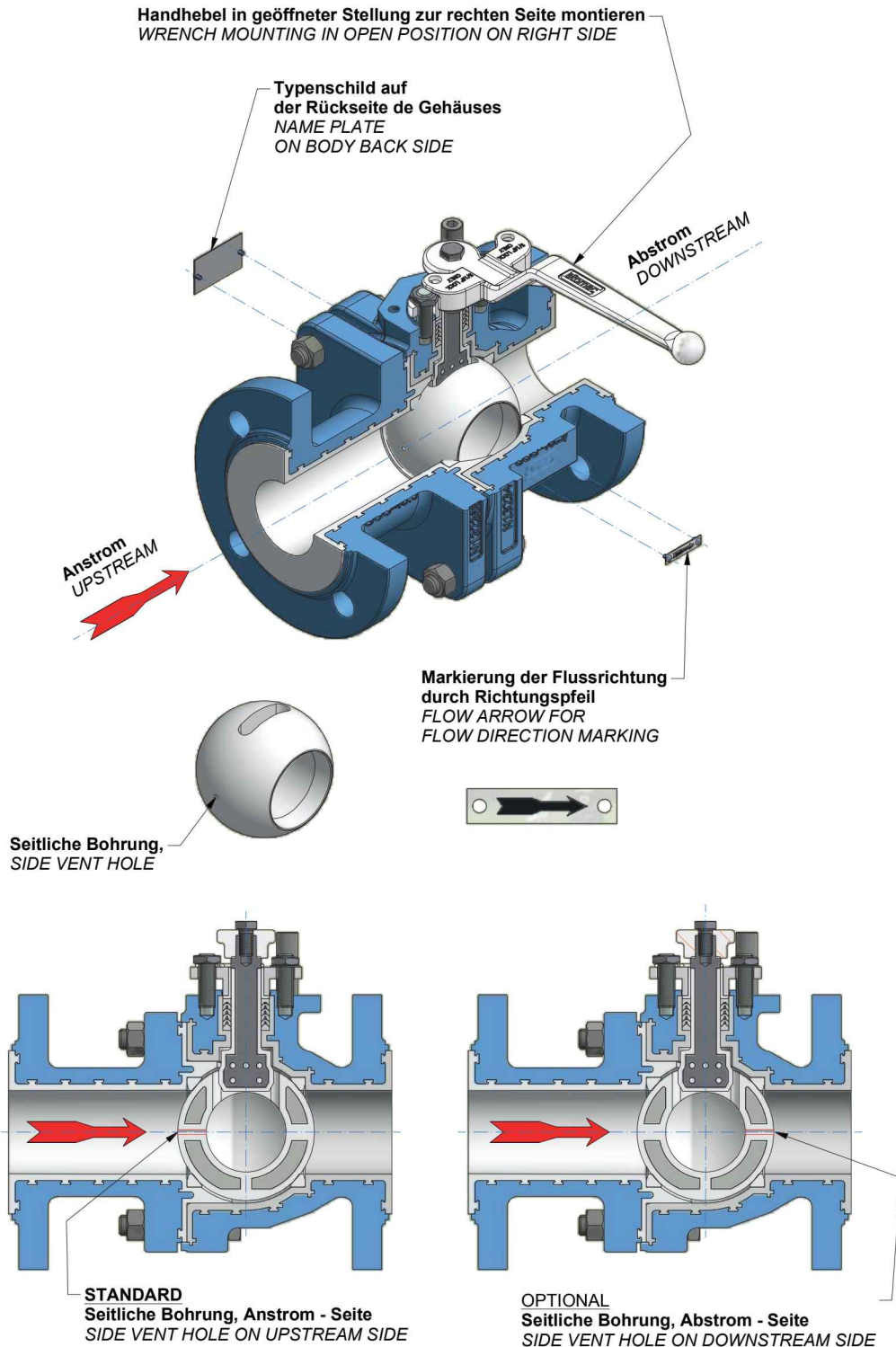

## Optional with C-ball

Handhebel in geöffneter Stellung zur rechten Seite montieren  
WRENCH MOUNTING IN OPEN POSITION ON RIGHT SIDE

Typenschild auf  
der Rückseite des Gehäuses  
NAME PLATE ON  
BODY BACK SIDE

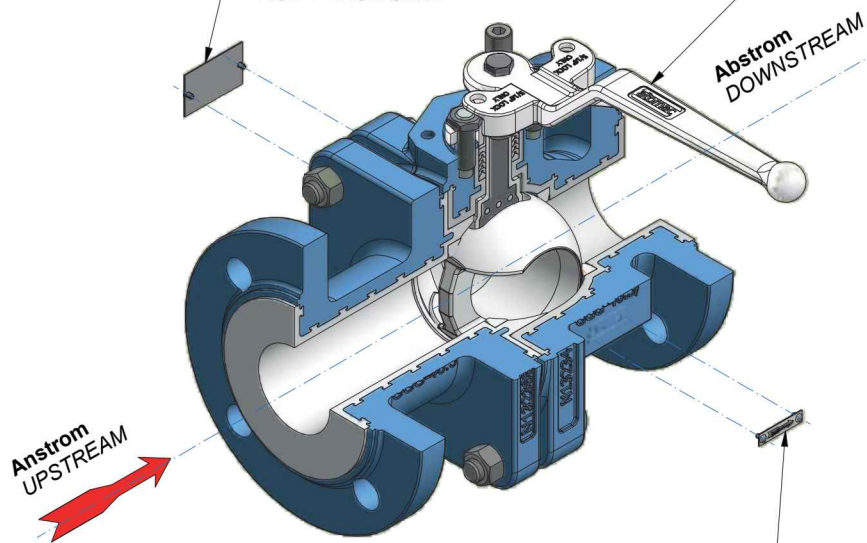

Markierung der Flussrichtung  
durch Richtungspfeil  
FLOW ARROW FOR  
FLOW DIRECTION MARKING

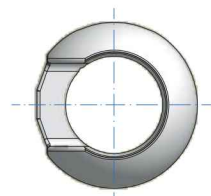

**C - Kugel**  
**C - BALL**

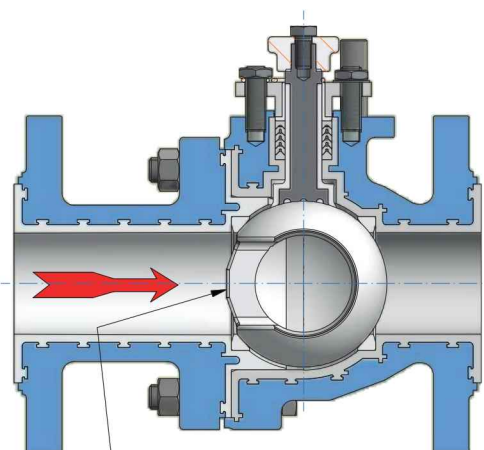

**C - Öffnung, Anstrom - Seite**  
**C - OPENING ON UPSTREAM SIDE**

**Optional with V-ball or S-ball**

